



**Upward Broadband**  
**Requests For Proposal**

**Communications Tower Concrete Foundation**

## Table of Contents

<b>1.0 Introduction</b>	<b>3</b>
<b>2.0 Scope of Work</b>	<b>4</b>
<b>3.0 General Instructions to Responders</b>	<b>4</b>
<b>4.0 Instructions to Proposers</b>	<b>6</b>
4.1 Schedule of Events	6
4.2 Proposers Examination of the RFP	7
4.3 Proposals Considered Firm	7
4.4 Withdrawal of Proposals	7
4.5 Required Insurance	7
4.6 Miscellaneous	8
4.7 Legal Conditions	8
<b>5.0 General Conditions</b>	<b>12</b>
5.1 Pricing, and Payments	12
5.2 Open Procurement	12
5.3 United States Made Steel Preference	12
5.4 Services and Product	12
5.5 Statement of Time	12
5.6 Qualifications of Proposers	13
5.7 Equal Employment Opportunity	13
5.8 Indemnification	13
5.9 Proposal Format	14
5.10 Submission Instructions:	15
5.11 Selection Process	15
5.12 Proposal Evaluation Criteria	16
<b>6.0 Terms and Conditions</b>	<b>16</b>
<b>7.0 Required Services</b>	<b>17</b>
<b>Appendix A</b>	<b>18</b>
<b>Appendix B</b>	<b>19</b>
<b>Appendix C</b>	<b>49</b>
<b>Non-Collusion Affidavit</b>	<b>53</b>
<b>DEBARMENT CERTIFICATION FORM</b>	<b>56</b>

\* Forms must be completed and returned with **all** other requested information to be considered.

## 1.0 Introduction

### ***Upward Broadband Request for Proposal Communications Tower Concrete Foundation***

Upward Broadband LLC, is seeking one or more Proposers to provide site preparation including rebar for a concrete foundation plus the delivery of concrete for a foundation that will house a self-supporting 190' communications tower. The tower must be installed in accordance with the tower design engineers' stamped drawings and additional details for the specifications required are located in Appendix C. The contractor(s) shall provide sufficient staffing, equipment, tools, materials, and supervision to accomplish the work requested. The successful bidder(s) will be required to provide all necessary labor, tools, supplies, materials, equipment, supervision, management, and transportation along with other incidentals necessary to perform these specifications.

This work falls under the Davis-Bacon and Related Acts and Pennsylvania Prevailing Wage Act and the selected Proposer will supply Upward Broadband with certified payroll documentation for the certified workers. The Davis-Bacon and the Pennsylvania Prevailing Wage Act will apply to contractors and subcontractors performing construction, alteration, or repair with federally funded or assisted contracts. Under this Act, contractors shall be required to pay wages specified in a wage determination made by the Pennsylvania Department of Labor. In addition, contractors shall be required to pay wages not less than once a week. A current copy of the prevailing wage is attached as Appendix B and the Proposer shall attach a copy of the prevailing wage to their bid proposal.

The primary contact for questions regarding this Proposal will be:

Art Horn  
Senior Project Manager  
Upward Broadband LLC  
3105 Lincoln Highway East  
Paradise, PA 17562  
717-809-7448  
[ahorn@upwardbroadband.com](mailto:ahorn@upwardbroadband.com)

## **2.0 Scope of Work**

The services below must be included in the scope of work of any submitted proposal, and must confirm with the project specifications provided by the tower manufacturer, the engineer for construction drawings and the projects specifications provided herein:

*The Proposer should note that all concrete work must be inspected per requirements of the building permit before pouring any concrete.*

1. Proposers should visit the project site prior to submitting a bid. That visit should be coordinated with Upward Broadband.
2. The site for the concrete tower foundation will be excavated by Upward Broadband.
3. After the successful construction testing and curing of the tower foundation completed by the awarded Proposer, Upward Broadband will backfill the area around the foundation.
4. The awarded Proposer should complete a constructability review prior to commencing the foundation layout as provided by the stamped engineer tower foundation drawings.
5. Awarded Proposer will provide sufficient staffing, transportation, supervision, equipment, tools, and materials to accomplish the work awarded.
6. The construction of the tower foundation deliverable consists of all work necessary to complete the foundation including the supply of all materials including rebar, rebar placement, concrete, and concrete pouring along with curing.
7. Any poured concrete that must be left open overnight shall be adequately barricaded and covered, if applicable.
8. The awarded Proposer will construct and use a concrete washout as detailed in the construction drawings for the tower site.
9. All poured-in-place concrete shall have an ultimate compressive strength of 4000 PSI minimum compressive strength after 28 days.
10. All reinforcement steel is deformed and meets the strength requirements of ASTM A615 Grade 60.
11. Embedded steel is to have a 3" minimum concrete cover.
12. Provide light broom finish on all concrete piers unless otherwise noted.

## **3.0 General Instructions to Responders**

1. Any additions to, alterations, erasures, or omissions of required information, or change of specifications, is done at the risk of the responder and may result in rejection of the submitted Proposal.
2. Submitting a Proposal when it is intended to sublet the contract is cause for rejection of your RFP or cancellation of the contract, unless approval is given in writing by Upward Broadband prior to the Proposal opening.
3. In case of error in the extension of prices, the unit price shall govern.

4. The contract will not be awarded to any corporations, firms or individuals who have failed previously in performing work or guaranteeing delivery with Upward Broadband.
5. It is expressly understood and agreed that any inspection of materials and workmanship by the purchasing or issuing department will in no way lessen the responsibility of the contractor or release him/her from obligations to perform and deliver satisfactory work and materials. The contractor agrees to pay the cost of all tests for defective materials and to allow the cost to be deducted from any money due him/her from Upward Broadband.
6. When the contract has been duly signed, the contractor may secure instructions from Upward Broadband pertaining to the procedure of the work or delivery
7. Upward Broadband reserves the right to reject any and or all RFP's or specifications when deemed as the best interest for the project. Upward Broadband may cancel the award at any time before the execution of the contract.
8. Upward Broadband will reject all materials that do not meet the required specifications.
9. The material and equipment should be delivered as follows:
  - a. All materials required for the tower foundation, the personnel and management, plus the concrete shall be delivered to the Mine Gap tower site, address provided to the winning proposer.
10. The party or parties proposing upon this Proposal to whom the award or awards are made may be required to enter into a contract with Upward Broadband within thirty (30) to sixty (60) days after notification. Failure of proposer to do so, shall result in the cancellation of the award and forfeiture of the Proposal bond and/or Proposal deposit which shall become the absolute property of Upward Broadband.
11. The responder or responders to whom the contract is awarded agree(s) to release Upward Broadband from all suits or action of any nature or description brought against it for or on account of the use of patents, appliances, products, or processes.
12. All RFP's must be made on Proposal blanks attached to these specifications and made part thereof, and must be emailed directly to [ahorn@upwardbroadband.com](mailto:ahorn@upwardbroadband.com) and [cpickel@upwardbroadband.com](mailto:cpickel@upwardbroadband.com) .
13. Responders must write or print the figures in ink or it must be typewritten.
14. A Proposal which is incomplete, obscure, conditional or unbalanced or which contains additions not called for or irregularities of any kind or alterations may be rejected.
15. Upward Broadband will not be liable for any costs incurred by the Proposers in preparing, submitting, or presenting Proposals.

## 4.0 Instructions to Proposers

### *Submission of Proposals*

It is intended that each Proposal furnish the information requested by this RFP. Unless specifically requested, promotional literature is not wanted and will not be considered to meet any of the requirements of this RFP.

Each Proposal shall include a Letter of Bid Intent, not to exceed two pages in length. The Proposal must bear the signature of an authorized representative of the Proposer making the offer and must designate by name not more than two individuals authorized to negotiate and sign the contract with Upward Broadband on behalf of the Proposer. The Letter of Bid Intent may also briefly set forth any particular information the Proposer wishes to bring to Upward Broadband attention.

The Proposer shall deliver one (1) copy of the Proposal electronically to:

[ahorn@upwardbroadband.com](mailto:ahorn@upwardbroadband.com)  
[cpickel@upwardbroadband.com](mailto:cpickel@upwardbroadband.com)

Upward Broadband reserves the right to accept or reject any or all Proposals.

### 4.1 Schedule of Events

October 22, 2024	RFP released to vendors
October 23, 2024	Notification of intent to bid should be emailed to <a href="mailto:ahorn@upwardbroadband.com">ahorn@upwardbroadband.com</a> and <a href="mailto:cpickel@upwardbroadband.com">cpickel@upwardbroadband.com</a> by 11:59 pm.
October 28, 2024	Last date for questions/clarifications for Proposers. Questions must be in writing, email is acceptable and encouraged.
<b>October 31, 2024</b>	<b>Response closed 11:59 pm EST (<u>NO PROPOSALS</u>) accepted after this time.</b>
November 4, 2024	Approximate Proposer notification
November 5, 2024	Begin work with selected Proposers on delivery details

## **4.2 Proposers Examination of the RFP**

Proposers shall examine all information and materials contained in and with this RFP. Failure to do so shall be at the Proposer's risk.

## **4.3 Proposals Considered Firm**

All Proposals in response to the RFP will be considered firm and cannot be withdrawn until 60 days after the scheduled Proposal due date or until the award of a contract to a Proposer, whichever comes first.

## **4.4 Withdrawal of Proposals**

Proposal may be withdrawn by written notice received by Upward Broadband, prior to the Proposal due date and time.

## **4.5 Required Insurance**

### ***Liability Insurance***

The Proposer shall carry insurance for contractor's liability, auto and truck, worker's compensation, owner's protective liability and fire with extended coverage along with builder's risk insurance.

Worker's Compensation Statutory  
Employer's Liability Statutory  
Automobile Liability \$1,000,000 combined single limit  
Comprehensive General Liability with following minimum coverage  
General Aggregate \$2,000,000  
Products-Comp/Ops Aggregate \$2,000,000  
Personal & Advertising Injury \$1,000,000  
Each Occurrence \$1,000,000  
Fire Damage \$50,000  
Medical Expense (any one person) \$5,000

The requirements of this clause are applicable to any and all subcontracts and subcontractors performing work under this contract. The Proposer shall not subcontract, transfer, or sublet any portion of this work covered by these specifications without prior written consent from Upward Broadband.

Certificates of Insurance acceptable to Upward Broadband shall be filed prior to any delivery of goods. These certificates shall contain a provision that coverages afforded under the policies will not be canceled or changed until at least ninety (90) days' from when written notice has

been given to Upward Broadband. The insurance shall also name Upward Broadband as an additional insured as its interests may appear.

The successful proposer shall be solely responsible for the compliance of subcontractors, if applicable, with the listed insurance requirements.

#### **4.6 Miscellaneous**

The successful Proposer will provide a project Proposal that includes a delivery date and flexibility for delays Upward Broadband may experience as a result of project site preparation.

A break-out of costs along with the total costs should be included along with details surrounding the Proposer payment timeline and requirements. The Proposer may not require all funds to be paid in full before the delivery of the requested product.

#### **4.7 Legal Conditions**

***Bid Bond*** - Each bid submitted must be accompanied by a certified check, cashier's check, or a treasurer's check drawn to the order of Upward Broadband in the amount of ten (10) percent of the total bid submitted by each bidder and shall be enclosed with the bid. In lieu of a check, a Bid Bond with surety acceptable to Upward Broadband in like amount may be tendered. All bonds shall be issued by companies such as will be acceptable to the owner, and which are authorized to transact business in Pennsylvania.

In the event the complete bid totals less than \$25,000, a bid bond or a certified check will not be required.

Checks will be returned promptly to all bidders after the successful bidder has furnished and properly signed all contract documents and submitted the required performance bond. The successful bidder must complete and deliver all contract documents within ten (10) business days from the date on the email in which Upward emails the award information. If the bidder to whom an award is made fails or refuses to execute the contract within the specified and allowed time for completion, Upward Broadband reserves the right to take action. This may involve deducting and retaining from the monies due to the bidder, or from the deposit required by the aforementioned paragraph, a sum sufficient to cover the difference between the awarded price and the price that Upward Broadband may be obliged to pay for procuring the work, service, and/or merchandise from other sources.

***Payment and Performance Bond*** - Upward Broadband is requiring the successful vendor to submit both a payment and performance bond. When the project with a subcontract value is between \$63,985 and \$250,000, the awarded proposer will provide a performance and payment bond in an amount equal to at least 50% of the total proposed price. If the subcontract value is in excess of \$250,000, the awarded proposer



will provide performance and payment bonds made payable to both the Commonwealth and Upward Broadband in an amount equal to 100% of the price specified in the proposed price.

**Litigation** - Any litigation pertaining to this RFP shall be under the laws of the Commonwealth of Pennsylvania and the County of Lancaster.

Prevailing Wage Act - This project will be subject to and governed by the provisions of the Pennsylvania Prevailing Wage Act. Bidders shall prepare their proposals after giving consideration to the applicability of said Pennsylvania Prevailing Wage Act and the Davis-Bacon and Related Acts to the work involved and all other laws and regulations, State and/or Federal, applicable to such projects.

The contractor and any subcontractor shall fully comply with all regulations under Act No. 442 is cited as the Pennsylvania Prevailing Wage Act, effective as of February 1, 1962, as amended by August 9, 1963 (Act No. 342) and the Davis-Bacon and Related Acts regulation, specifically 29 C.F.R. Section 5.5.

There shall be paid each mechanic or laborers of the contractor or any subcontractor engaged in work on the Project under the contract in the trade or occupation listed below, not less than the hourly wage rate set opposite the same, regardless of any contractual relationship which may be alleged to exist between the contractor or any subcontractor and such laborers and mechanics, as set forth in the applicable Wage Rate Decisions of the Commonwealth of Pennsylvania, Department of Labor and Industry.

Requirements for Prevailing Wage Compliance

- i. The work performed is subject to and the winning Proposer shall comply with all requirements of Pennsylvania's Prevailing Wage Act and the Davis-Bacon and Related Acts
- ii. All applicable Prevailing Wage Rate sheets will be provided with weekly payroll to Upward Broadband Staff Accountant.
- iii. The winning Proposer shall pay at least the wage rates as in the Prevailing Wage Rate Sheets, Appendix B, and shall comply with the conditions of the Pennsylvania's Prevailing Wage Act and the Davis-Bacon and Related Acts, and the regulations issued to assure the full and proper payment of the rates.
- iv. Workmen employed in the performance of the Subcontract shall be paid at least the general prevailing minimum wage rates, including contributions for employee benefits, and other provisions to assure payment as set forth in the Prevailing Wage Acts.

v. Prevailing Wage Act requirements apply to work performed on this project by the winning Proposer and to any work completed by sub-subcontractors, if applicable.

vi. All workmen employed or working on the public work shall be paid unconditionally, regardless of whether any contractual relationship exists or the nature of any contractual relationship which may be alleged to exist between any contractor, subcontractor and workmen, not less than once a week without deduction or rebate on any account, either directly or indirectly, except authorized deductions, the full amounts due at the time of payment, computed at the rates applicable to the time worked in the appropriate classification. Nothing in the contract, the Act or these regulations shall prohibit the payment of more than the general prevailing minimum wage rates as determined by the Secretary to any workman on public work.

vii. The contractor and each subcontractor, if applicable, shall post for the entire period of construction, the wage determination decisions of the Secretary, including the effective date of any changes thereof, site of the work and each place or places used by them to pay workmen their wages.

viii. The contractor and all subcontractors, if applicable, shall keep an accurate record showing the name, craft and/or classification, number of hours worked per day, and the actual hourly rate of wage paid (including employee benefits) to each workman employed by him in connection with the public work and such record must include any deductions from each workman. The record shall be preserved for five (5) years from the date of payment, provided to Upward Broadband's Staff Accountant weekly, and shall be open at all reasonable hours to the inspection of the public body awarding the contract and to the Secretary or his duly authorized representatives.

ix. Apprentices shall be limited to such number as shall be in accordance with a bona fide apprenticeship program registered with, and approved by, the Pennsylvania Apprenticeship and Training Council and only apprentices whose training and employment are in full compliance with the provisions of the Apprenticeship and Training Act approved July 14, 1961 (Act No. 304) and the Rules and Regulations issued pursuant thereto shall be employed on the work project. Any workmen using the tools of a craft who does not qualify as an apprentice within the provisions of this subsection shall be paid the rate predetermined for journeymen in that particular craft and/or classification.

x. Wages shall be paid without any deductions except authorized deductions. Employers not parties to a contract requiring contributions for employee benefits which the Secretary has determined to be included in the general prevailing minimum wage rate shall pay the monetary equivalent thereof directly to the workmen.

xi. Payment of compensation to workmen for work performed on public work on a lump sum basis, or a piece work system, or a price certain for the completion of a certain

amount of work, or the production of a certain results shall be deemed a violation of the Act and these Regulations, regardless of the average hourly earnings resulting therefrom.

xii. Each contractor and each subcontractor, if applicable, shall file a statement each week and a final statement at the conclusion of work on the contract with the contracting agency, under oath, and in form satisfactory to the Staff Accountant at Upward Broadband, certifying that all workmen have been paid wages in strict conformity with the provisions of the contract as prescribed by this Section 3 of these Regulations, or if any wages remain unpaid to set forth the amount of wages due and owing to each workman respectively.



## **5.0 General Conditions**

### **5.1 Pricing, and Payments**

Negotiated prices shall be firm and not subject to increase during the term of any contractual agreement arising between Upward Broadband and the successful Proposer as a result of the RFP.

### **5.2 Open Procurement**

Upward Broadband reserves the right to purchase more services at the unit price offered in the Proposers system, unless the Proposer specifically and explicitly limits the response in this regard. Upward Broadband reserves the right to negotiate with Proposers regarding variations to the original Proposal that may be in the best interest of Upward Broadband. Upward Broadband reserves the right to accept or reject any and or all Proposals.

### **5.3 United States Made Steel Preference**

Upward Broadband prefers the use of United States made steel for the proposed project. With US made steel, the Proposer will need to include a statement within their response that their pricing includes the use of US steel.

If the Proposer states in the Proposal process they are using US Steel and is successful in securing the project, a certificate must be produced validating that the steel used was manufactured in the United States.

### **5.4 Services and Product**

All preparation work for the concrete foundation plus the concrete work itself shall be performed by qualified and experienced personnel. The work must be completed as per the specifications provided by the designated tower supplier leveraging the documents provided by said tower supplier.

### **5.5 Statement of Time**

A period of time, unless stated as a number of workdays, shall include Saturdays and Sundays. Holidays should **not** be included.

## **5.6 Qualifications of Proposers**

The Proposers must demonstrate they are in compliance with all state, county, and local laws and ordinances and are not delinquent with all taxing agencies including federal, state, county, and local throughout the United States.

## **5.7 Equal Employment Opportunity**

During the performance of this contract, the Proposer agrees as follows: The Proposer will not discriminate against any employee or applicant for employment because of race, color, religion, sex, age, handicapped status, or national origin. The Proposer will take affirmative action to ensure that applicants are employed, and the Employees are treated during employment without regard to their race, color, religion, sex, or national origin. Such action shall include, but not be limited to, the following; employment upgrading, demotion, or transfer, recruitment or recruitment advertising, layoff or termination, rates of pay or other forms of compensation, and selection for training, including apprenticeship. The Proposer agrees to post in conspicuous places, available to employees and applicants for employment, notices setting forth the provisions of this nondiscrimination clause. In the event of the Proposer's noncompliance with the nondiscrimination clause of the contract or with any of such rules, regulations, or orders this contract may be canceled, terminated or suspended in whole or in part and the contractor may be declared ineligible for further contracts with Upward Broadband.

The Proposer must take all necessary affirmative steps to assure that minority businesses, womens' business enterprises, and labor surplus area firms are used whenever possible.

## **5.8 Indemnification**

The Proposer will indemnify, defend and hold Upward Broadband, its Manager and Council, its employees and agents harmless from all claims, demands, costs, expenses, liabilities and losses including reasonable attorney's fees which may arise against Upward Broadband, employees and agents as a consequence of any action or claim arising out of the Proposer's malfeasance, neglect or omission.

The Proposer will be responsible for any damage to property caused by Proposer or his agents. The Proposer further covenants and agrees to assume and does hereby assume all liability for, and shall and does agree to, indemnity and save harmless the participating entities against any and all loss, costs, suits, claims, charges or damages arising from injuries sustained by mechanics, laborers, workmen, or by any person or persons whatsoever, to their persons or property, whether employed in and about the said work or otherwise, by reason of any accidents, damages or injuries, torts, or trespasses happening in and about, or in any way incident to, or by reason of the performance of this contract and the performance of said work

and labor, including costs, counsel fees, and all expenses of defense, and agrees to carry the usual property damage and liability insurance to furnish certificates thereof, when required by the participating entities or the Joint Purchasing Board.

## 5.9 Proposal Format

The Proposal shall contain the following sections, each clearly labeled with the section number at the top of the page, in the order and format described below:

In the case the proposer is a dealer and not a manufacturer, the dealer is to assume all of the responsibilities that are outlined in this RFP.

<b><u>Section</u></b>	<b><u>Description</u></b>
1.	Letter of Bid Intent, signed by a principal of the Proposer who is authorized to negotiate on behalf of the Proposer.
2.	Executive Summary.
3.	Proposer using steel made in the United States must make that certification within their Proposal.
4.	Exceptions to the General Conditions Section.
5.	Explanation of “Exceptions” taken in (3) above. Note that any “clarifications” provided for sections or numbered paragraphs that have been asserted to be in compliance in (4) above will generally negate a “comply” statement; this will cause the Proposer to be judged non-compliant with that section or paragraph. This does not necessarily mean, however, the Proposal will be rejected.
6.	Company description, qualifications to include: EIN, and Bank reference.
7.	At least three (3) references of similar foundations furnished with contact name, phone number, email address, address of customer, approximate date installed, and actual project timeline from award of contract through final equipment shipment to acceptance.
8.	Proposed services and any ongoing support,

warranty, and maintenance recommended.

9. A project management Proposal including the overall project schedule from order acceptance to site delivery. If the Proposer is a dealer and not a manufacturer it is their responsibility to provide this service.
10. Delivery schedule and the flexibility that exists with that schedule.
11. Completed Cost Sheets (Appendix A), with comprehensive, itemized pricing for each element of the Proposer's Proposal and a summary of the total cost for all proposed elements. Both non-recurring and recurring (if any) costs shall be listed. If additional space is needed, an additional sheet can be included. The Proposer should include any and/or all payment requirements.
12. Resumes of key staff involved in the design, implementation, and management of the project.
13. Non-Collusion Affidavit
14. Debarment Certification Form

### **5.10 Submission Instructions:**

All submissions are to be sent electronically to [ahorn@upwardbroadband.com](mailto:ahorn@upwardbroadband.com) and [cpickel@upwardbroadband.com](mailto:cpickel@upwardbroadband.com) with all required documentation.

**The timestamp must be prior to 11:59 pm EST on October 28, 2024.**

### **5.11 Selection Process**

The selection of a Proposer to provide site preparation, personnel and concrete by Upward Broadband is an important task. Upward Broadband recognizes that several Proposers can provide the equipment and support that would adequately meet the needs of Upward Broadband. Upward Broadband will exercise both objective and subjective rationale in this selection process. This process is outlined in the upcoming pages. This RFP is intended to provide interested Proposers with consistent information regarding the conditions for submitting Proposals. In responding to this RFP, Proposers shall adhere to the established format. In complying with the format, comparable objective data will be available for review and analysis by Upward Broadband.

## 5.12 Proposal Evaluation Criteria

The criteria upon which the evaluation of the Proposals will be based, but is not limited to, the following:

1. Total cost of product and services required by Upward Broadband, and all other items constituting total price. A contract will not necessarily be awarded for the lowest price.
2. Proposers overall past performance and support including reputation with customers, reports, and overall ability to commit to this project.
3. Completeness of Proposal.
4. Quality and depth of references.
5. Quality and extent of the documentation to be provided.
6. Delivery timeframe commitments.
7. Warranty, and maintenance support if required, terms and conditions.
8. Fewest exceptions to specifications.

Upward Broadband will select the Proposer who, in their opinion, has made the best overall Proposal and shall award the contract to that Proposer. Final selection will be made by Upward Broadband and they may reject any or all received Proposals.

## 6.0 Terms and Conditions

### ***Warranty and Extended Maintenance***

Proposer is to clearly identify in a synopsis the details of any manufacturer's warranty or maintenance for the product, if applicable.

### ***Warranty***

1. Proposer to provide all details of the warranty or maintenance accompanying the work.



## 7.0 Required Services

### *Implementation*

The successful proposer will have to coordinate the work, delivery schedules and any offloading requirements with Upward Broadband Senior Project Manager, Art Horn or Foreman, Marlin Hostetter.



**Appendix A**

**Upward Broadband  
Concrete Delivery**

**Cost Sheet**

Proposers listed and total cost captured on this sheet should include all materials for preparing the tower site for the concrete foundation plus all materials to complete; the labor, the rebar, and the concrete itself for the foundation.

**TOTAL**

_____	_____
_____	_____
_____	_____
_____	_____
_____	_____
_____	_____

**TOTAL**      \$ \_\_\_\_\_

## Appendix B

### BUREAU OF LABOR LAW COMPLIANCE PREVAILING WAGES PROJECT RATES

Project Name:	Rural Broadband Infrastructure Expansion in the Alleghenies
Awarding Agency:	Huntingdon County/NTIA
Contract Award Date:	3/1/2022
Serial Number:	23-06259
Project Classification:	Building/Heavy/Highway
Determination Date:	7/14/2023
Assigned Field Office:	Altoona
Field Office Phone Number:	(814)940-6224
Toll Free Phone Number:	
Project County:	Fulton County

**BUREAU OF LABOR LAW COMPLIANCE  
PREVAILING WAGES PROJECT RATES**

Project: 23-06259 - Building	Effective Date	Expiration Date	Hourly Rate	Fringe Benefits	Total
Asbestos & Insulation Workers	7/27/2022		\$35.80	\$30.01	\$65.81
Asbestos & Insulation Workers	6/26/2023		\$38.70	\$29.11	\$67.81
Asbestos & Insulation Workers	7/1/2024		\$35.80	\$34.06	\$69.86
Boilermaker (Commercial, Institutional, and Minor Repair Work)	1/1/2019		\$29.26	\$18.48	\$47.74
Boilermakers	1/1/2023		\$51.27	\$35.30	\$86.57
Bricklayer (Pointer, Cleaner, Caulker, Cement Mason, Plasterer, Tile Setter)	5/1/2018		\$28.15	\$22.45	\$50.60
Bricklayer	12/1/2022		\$34.14	\$22.38	\$56.52
Carpenters, Drywall Hangers, Framers, Instrument Men, Lathers, Soft Floor Layers	6/1/2022		\$32.05	\$17.87	\$49.92
Cement Finishers & Plasterers	5/1/2022		\$29.38	\$20.98	\$50.36
Cement Masons	5/1/2023		\$32.90	\$22.70	\$55.60
Drywall Finisher	6/1/2022		\$31.50	\$21.06	\$52.56
Drywall Finisher	6/1/2023		\$31.89	\$22.92	\$54.81
Drywall Finisher	6/1/2024		\$33.51	\$23.80	\$57.31
Electricians & Telecommunications Installation Technician	12/26/2022		\$48.31	\$29.29	\$77.60
Elevator Constructor	1/1/2023		\$53.93	\$38.34	\$92.27
Glazier	9/1/2021		\$24.55	\$23.05	\$47.60
Glazier	9/1/2022		\$24.90	\$24.45	\$49.35
Iron Workers	11/1/2022		\$30.06	\$23.34	\$53.40
Laborers (Class 01 - See notes)	1/1/2023		\$25.31	\$17.29	\$42.60
Laborers (Class 01 - See notes)	1/1/2024		\$26.31	\$17.79	\$44.10
Laborers (Class 02 - See notes)	1/1/2023		\$28.06	\$17.29	\$45.35
Laborers (Class 02 - See notes)	1/1/2024		\$29.56	\$17.79	\$47.35
Laborers (Class 03 - See notes)	1/1/2023		\$27.66	\$17.29	\$44.95
Laborers (Class 03 - See notes)	1/1/2024		\$28.66	\$17.79	\$46.45
Laborers (Class 04 - See notes)	1/1/2023		\$24.31	\$17.29	\$41.60
Laborers (Class 04 - See notes)	1/1/2024		\$25.31	\$17.79	\$43.10
Landscape Laborer (Skilled)	1/1/2020		\$21.64	\$16.98	\$38.62
Landscape Laborer (Skilled)	1/1/2023		\$23.79	\$18.28	\$42.07
Landscape Laborer (Skilled)	1/1/2024		\$24.79	\$18.53	\$43.32
Landscape Laborer (Skilled)	1/1/2025		\$25.79	\$18.78	\$44.57
Landscape Laborer (Skilled)	1/1/2026		\$26.79	\$19.03	\$45.82
Landscape Laborer (Tractor Operator)	1/1/2020		\$21.94	\$16.98	\$38.92
Landscape Laborer (Tractor Operator)	1/1/2023		\$24.09	\$18.28	\$42.37
Landscape Laborer (Tractor Operator)	1/1/2024		\$25.09	\$18.53	\$43.62
Landscape Laborer (Tractor Operator)	1/1/2025		\$26.09	\$18.78	\$44.87
Landscape Laborer (Tractor Operator)	1/1/2026		\$27.09	\$19.03	\$46.12
Landscape Laborer	1/1/2023		\$23.37	\$18.28	\$41.65
Landscape Laborer	1/1/2024		\$24.37	\$18.53	\$42.90
Landscape Laborer	1/1/2025		\$25.37	\$18.78	\$44.15
Landscape Laborer	1/1/2026		\$26.37	\$19.03	\$45.40
Marble Finisher	6/1/2015		\$22.55	\$12.79	\$35.34
Marble Mason	12/1/2014		\$19.43	\$10.00	\$29.43

Commonwealth of Pennsylvania  
Report Date: 7/17/2023

Department of Labor & Industry  
Page 2 of 7

**BUREAU OF LABOR LAW COMPLIANCE  
PREVAILING WAGES PROJECT RATES**

Project: 23-06259 - Building	Effective Date	Expiration Date	Hourly Rate	Fringe Benefits	Total
Millwright	6/1/2020		\$41.68	\$20.32	\$62.00
Operators (Class 01 - see notes)	7/1/2022		\$34.17	\$20.62	\$54.79
Operators (Class 01 - see notes)	7/1/2023		\$35.87	\$20.92	\$56.79
Operators (Class 01 - see notes)	7/1/2024		\$36.87	\$21.42	\$58.29
Operators (Class 02 -see notes)	7/1/2022		\$29.55	\$20.62	\$50.17
Operators (Class 02 -see notes)	7/1/2023		\$31.25	\$20.92	\$52.17
Operators (Class 02 -see notes)	7/1/2024		\$32.87	\$21.42	\$54.29
Operators (Class 03 - See notes)	7/1/2022		\$27.00	\$20.62	\$47.62
Operators (Class 03 - See notes)	7/1/2023		\$28.70	\$20.92	\$49.62
Operators (Class 03 - See notes)	7/1/2024		\$29.70	\$21.42	\$51.12
Operators (Class 04 - Chief of Party (Surveying and Layout))	7/1/2022		\$26.60	\$20.62	\$47.22
Operators (Class 04 - Chief of Party (Surveying and Layout))	7/1/2023		\$28.30	\$20.92	\$49.22
Operators (Class 04 - Chief of Party (Surveying and Layout))	7/1/2024		\$29.30	\$21.42	\$50.72
Operators (Class 04 - Instrument Person (Surveying & Layout))	7/1/2022		\$25.60	\$20.62	\$46.22
Operators (Class 04 - Instrument Person (Surveying & Layout))	7/1/2023		\$27.30	\$20.92	\$48.22
Operators (Class 04 - Instrument Person (Surveying & Layout))	7/1/2024		\$28.30	\$21.42	\$49.72
Operators (Class 04 - Rodman/Chainman (Surveying and Layout))	7/1/2022		\$25.15	\$20.62	\$45.77
Operators (Class 04 - Rodman/Chainman (Surveying and Layout))	7/1/2023		\$26.85	\$20.92	\$47.77
Operators (Class 04 - Rodman/Chainman (Surveying and Layout))	7/1/2024		\$27.85	\$21.42	\$49.27
Painters Class 6 (see notes)	6/1/2022		\$29.50	\$22.82	\$52.32
Pile Driver Divers (Building, Heavy, Highway)	1/1/2023		\$58.70	\$21.22	\$79.92
Pile Driver Divers (Building, Heavy, Highway)	1/1/2024		\$60.95	\$21.97	\$82.92
Pile Driver Divers (Building, Heavy, Highway)	1/1/2025		\$62.82	\$22.72	\$85.54
Pile Driver Divers (Building, Heavy, Highway)	1/1/2026		\$64.70	\$23.47	\$88.17
Piledrivers	1/1/2023		\$39.13	\$21.22	\$60.35
Piledrivers	1/1/2024		\$40.63	\$21.97	\$62.60
Piledrivers	1/1/2025		\$41.88	\$22.72	\$64.60
Piledrivers	1/1/2026		\$43.13	\$23.47	\$66.60
Plasterers	5/1/2023		\$31.33	\$20.83	\$52.16
Plumber/Pipefitter	5/1/2023		\$41.36	\$29.72	\$71.08
Pointers, Caulkers, Cleaners	12/1/2022		\$35.47	\$20.88	\$56.35
Roofers (Composition)	5/1/2023		\$42.63	\$34.62	\$77.25
Roofers (Shingle)	5/1/2020		\$29.50	\$21.25	\$50.75
Roofers (Slate & Tile)	5/1/2020		\$32.50	\$21.25	\$53.75
Sheet Metal Workers	6/1/2022		\$40.22	\$41.01	\$81.23
Sheet Metal Workers	6/1/2023		\$41.41	\$42.32	\$83.73
Sign Makers and Hangars	7/15/2022		\$30.54	\$24.35	\$54.89
Sprinklerfitters	4/1/2023		\$44.33	\$28.04	\$72.37

**BUREAU OF LABOR LAW COMPLIANCE  
PREVAILING WAGES PROJECT RATES**

Project: 23-06259 - Building	Effective Date	Expiration Date	Hourly Rate	Fringe Benefits	Total
Stone Masons	12/1/2022		\$38.56	\$23.61	\$62.17
Terrazzo Finisher	12/1/2022		\$36.13	\$18.03	\$54.16
Terrazzo Mechanics	12/1/2022		\$35.49	\$20.32	\$55.81
Tile Finisher	12/1/2022		\$28.76	\$17.34	\$46.10
Tile Setter	12/1/2022		\$35.64	\$21.81	\$57.45
Truckdriver class 1(see notes)	1/1/2023		\$33.04	\$22.13	\$55.17
Truckdriver class 1(see notes)	1/1/2024		\$34.79	\$22.63	\$57.42
Truckdriver class 1(see notes)	1/1/2025		\$36.29	\$23.13	\$59.42
Truckdriver class 1(see notes)	1/1/2026		\$37.79	\$23.63	\$61.42
Truckdriver class 2 (see notes)	1/1/2023		\$33.50	\$22.43	\$55.93
Truckdriver class 2 (see notes)	1/1/2024		\$35.25	\$22.93	\$58.18
Truckdriver class 2 (see notes)	1/1/2025		\$36.75	\$23.43	\$60.18
Truckdriver class 2 (see notes)	1/1/2026		\$38.25	\$23.93	\$62.18
Truckdriver class 3 (see notes)	1/1/2016		\$28.10	\$16.88	\$44.98
Window Film / Tint Installer	10/1/2019		\$25.00	\$2.63	\$27.63

**BUREAU OF LABOR LAW COMPLIANCE  
PREVAILING WAGES PROJECT RATES**

Project: 23-06259 - Heavy/Highway	Effective Date	Expiration Date	Hourly Rate	Fringe Benefits	Total
Carpenter	1/1/2023		\$38.35	\$20.59	\$58.94
Carpenter	1/1/2024		\$39.85	\$21.34	\$61.19
Carpenter	1/1/2025		\$41.10	\$22.09	\$63.19
Carpenter	1/1/2026		\$42.35	\$22.84	\$65.19
Carpenter Welder	1/1/2023		\$39.85	\$20.59	\$60.44
Carpenter Welder	1/1/2024		\$41.35	\$21.34	\$62.69
Carpenter Welder	1/1/2025		\$42.60	\$22.09	\$64.69
Carpenter Welder	1/1/2026		\$43.85	\$22.84	\$66.69
Cement Finishers	1/1/2023		\$34.14	\$25.05	\$59.19
Cement Finishers	1/1/2024		\$35.14	\$26.30	\$61.44
Cement Finishers	1/1/2025		\$35.94	\$27.50	\$63.44
Cement Masons	1/1/2020		\$32.84	\$21.10	\$53.94
Electric Lineman	5/29/2023		\$52.56	\$29.99	\$82.55
Electric Lineman	6/3/2024		\$53.97	\$31.05	\$85.02
Iron Workers	5/1/2021		\$28.91	\$22.99	\$51.90
Laborers (Class 01 - See notes)	1/1/2023		\$29.85	\$25.50	\$55.35
Laborers (Class 01 - See notes)	1/1/2024		\$32.10	\$25.50	\$57.60
Laborers (Class 01 - See notes)	1/1/2025		\$33.60	\$26.00	\$59.60
Laborers (Class 01 - See notes)	1/1/2026		\$34.60	\$27.00	\$61.60
Laborers (Class 02 - See notes)	1/1/2023		\$30.01	\$25.50	\$55.51
Laborers (Class 02 - See notes)	1/1/2024		\$32.26	\$25.50	\$57.76
Laborers (Class 02 - See notes)	1/1/2025		\$33.76	\$26.00	\$59.76
Laborers (Class 02 - See notes)	1/1/2026		\$34.76	\$27.00	\$61.76
Laborers (Class 03 - See notes)	1/1/2023		\$30.50	\$25.50	\$56.00
Laborers (Class 03 - See notes)	1/1/2024		\$32.75	\$25.50	\$58.25
Laborers (Class 03 - See notes)	1/1/2025		\$34.25	\$26.00	\$60.25
Laborers (Class 03 - See notes)	1/1/2026		\$35.25	\$27.00	\$62.25
Laborers (Class 04 - See notes)	1/1/2023		\$30.95	\$25.50	\$56.45
Laborers (Class 04 - See notes)	1/1/2024		\$33.20	\$25.50	\$58.70
Laborers (Class 04 - See notes)	1/1/2025		\$34.70	\$26.00	\$60.70
Laborers (Class 04 - See notes)	1/1/2026		\$35.70	\$27.00	\$62.70
Laborers (Class 05 - See notes)	1/1/2023		\$31.36	\$25.50	\$56.86
Laborers (Class 05 - See notes)	1/1/2024		\$33.61	\$25.50	\$59.11
Laborers (Class 05 - See notes)	1/1/2025		\$35.11	\$26.00	\$61.11
Laborers (Class 05 - See notes)	1/1/2026		\$36.11	\$27.00	\$63.11
Laborers (Class 06 - See notes)	1/1/2023		\$28.20	\$25.50	\$53.70
Laborers (Class 06 - See notes)	1/1/2024		\$30.45	\$25.50	\$55.95
Laborers (Class 06 - See notes)	1/1/2025		\$31.95	\$26.00	\$57.95
Laborers (Class 06 - See notes)	1/1/2026		\$32.95	\$27.00	\$59.95
Laborers (Class 07 - See notes)	1/1/2023		\$30.85	\$25.50	\$56.35
Laborers (Class 07 - See notes)	1/1/2024		\$33.10	\$25.50	\$58.60
Laborers (Class 07 - See notes)	1/1/2025		\$34.60	\$26.00	\$60.60
Laborers (Class 07 - See notes)	1/1/2026		\$35.60	\$27.00	\$62.60
Laborers (Class 08 - See notes)	1/1/2023		\$32.35	\$25.50	\$57.85

**BUREAU OF LABOR LAW COMPLIANCE  
PREVAILING WAGES PROJECT RATES**

Project: 23-06259 - Heavy/Highway	Effective Date	Expiration Date	Hourly Rate	Fringe Benefits	Total
Laborers (Class 08 - See notes)	1/1/2024		\$34.60	\$25.50	\$60.10
Laborers (Class 08 - See notes)	1/1/2025		\$36.10	\$26.00	\$62.10
Laborers (Class 08 - See notes)	1/1/2026		\$37.10	\$27.00	\$64.10
Millwright	6/1/2020		\$41.68	\$20.32	\$62.00
Operators (Class 01 - see notes)	1/1/2023		\$36.50	\$23.58	\$60.08
Operators (Class 01 - see notes)	1/1/2024		\$38.30	\$24.03	\$62.33
Operators (Class 01 - see notes)	1/1/2025		\$40.10	\$24.23	\$64.33
Operators (Class 02 -see notes)	1/1/2023		\$36.22	\$23.58	\$59.80
Operators (Class 02 -see notes)	1/1/2024		\$38.02	\$24.03	\$62.05
Operators (Class 02 -see notes)	1/1/2025		\$39.82	\$24.23	\$64.05
Operators (Class 03 - See notes)	1/1/2023		\$32.58	\$23.58	\$56.16
Operators (Class 03 - See notes)	1/1/2024		\$34.38	\$24.03	\$58.41
Operators (Class 03 - See notes)	1/1/2025		\$36.18	\$24.23	\$60.41
Operators (Class 04 - See notes)	1/1/2023		\$32.09	\$23.58	\$55.67
Operators (Class 04 - See notes)	1/1/2024		\$33.89	\$24.03	\$57.92
Operators (Class 04 - See notes)	1/1/2025		\$35.69	\$24.23	\$59.92
Operators (Class 05 - See notes)	1/1/2023		\$31.88	\$23.58	\$55.46
Operators (Class 05 - See notes)	1/1/2024		\$33.68	\$24.03	\$57.71
Operators (Class 05 - See notes)	1/1/2025		\$35.48	\$24.23	\$59.71
Operators Class 1-A	1/1/2023		\$39.50	\$23.58	\$63.08
Operators Class 1-A	1/1/2024		\$41.30	\$24.03	\$65.33
Operators Class 1-A	1/1/2025		\$43.10	\$24.23	\$67.33
Operators Class 1-B	1/1/2023		\$38.50	\$23.58	\$62.08
Operators Class 1-B	1/1/2024		\$40.30	\$24.03	\$64.33
Operators Class 1-B	1/1/2025		\$42.10	\$24.23	\$66.33
Painters Class 1 (see notes)	6/1/2022		\$34.45	\$22.82	\$57.27
Painters Class 2 (see notes)	6/1/2019		\$35.25	\$20.06	\$55.31
Painters Class 3 (see notes)	6/1/2022		\$36.77	\$22.82	\$59.59
Painters Class 4 (see notes)	6/1/2019		\$28.20	\$20.06	\$48.26
Painters Class 5 (see notes)	6/1/2019		\$22.91	\$20.06	\$42.97
Pile Driver Divers (Building, Heavy, Highway)	1/1/2023		\$58.70	\$21.22	\$79.92
Pile Driver Divers (Building, Heavy, Highway)	1/1/2024		\$60.95	\$21.97	\$82.92
Pile Driver Divers (Building, Heavy, Highway)	1/1/2025		\$62.82	\$22.72	\$85.54
Pile Driver Divers (Building, Heavy, Highway)	1/1/2026		\$64.70	\$23.47	\$88.17
Piledrivers	1/1/2023		\$39.13	\$21.22	\$60.35
Piledrivers	1/1/2024		\$40.63	\$21.97	\$62.60
Piledrivers	1/1/2025		\$41.88	\$22.72	\$64.60
Piledrivers	1/1/2026		\$43.13	\$23.47	\$66.60
Steamfitters (Heavy and Highway - Gas Distribution)	5/1/2022		\$48.43	\$40.28	\$88.71
Truckdriver class 1(see notes)	1/1/2023		\$33.64	\$22.52	\$56.16
Truckdriver class 1(see notes)	1/1/2024		\$35.39	\$23.02	\$58.41
Truckdriver class 1(see notes)	1/1/2025		\$36.89	\$23.52	\$60.41
Truckdriver class 1(see notes)	1/1/2026		\$38.39	\$24.02	\$62.41
Truckdriver class 2 (see notes)	1/1/2023		\$33.50	\$22.43	\$55.93



**BUREAU OF LABOR LAW COMPLIANCE  
PREVAILING WAGES PROJECT RATES**

<b>Project: 23-06259 - Heavy/Highway</b>	<b>Effective Date</b>	<b>Expiration Date</b>	<b>Hourly Rate</b>	<b>Fringe Benefits</b>	<b>Total</b>
Truckdriver class 2 (see notes)	1/1/2024		\$35.25	\$22.93	\$58.18
Truckdriver class 2 (see notes)	1/1/2025		\$36.75	\$23.43	\$60.18
Truckdriver class 2 (see notes)	1/1/2026		\$38.25	\$23.93	\$62.18
Truckdriver class 3 (see notes)	1/1/2019		\$29.45	\$19.73	\$49.18

"General Decision Number: PA20230002 07/28/2023

Superseded General Decision Number: PA20220002

State: Pennsylvania

Construction Types: Heavy and Highway

Counties: Allegheny, Armstrong, Beaver, Bedford, Blair, Butler, Cambria, Cameron, Centre, Clarion, Clearfield, Clinton, Crawford, Elk, Erie, Fayette, Forest, Franklin, Fulton, Greene, Huntingdon, Indiana, Jefferson, Lawrence, McKean, Mercer, Mifflin, Potter, Somerset, Venango, Warren, Washington and Westmoreland Counties in Pennsylvania.

HEAVY AND HIGHWAY CONSTRUCTION PROJECTS (excluding sewer grouting projects and excluding sewage and water treatment plant projects)

Note: Contracts subject to the Davis-Bacon Act are generally required to pay at least the applicable minimum wage rate required under Executive Order 14026 or Executive Order 13658. Please note that these Executive Orders apply to covered contracts entered into by the federal government that are subject to the Davis-Bacon Act itself, but do not apply to contracts subject only to the Davis-Bacon Related Acts, including those set forth at 29 CFR 5.1(a)(2)-(60).

<p>If the contract is entered into on or after January 30, 2022, or the contract is renewed or extended (e.g., an option is exercised) on or after January 30, 2022:</p>	<ul style="list-style-type: none"> <li>. Executive Order 14026 generally applies to the contract.</li> <li>. The contractor must pay all covered workers at least \$16.20 per hour (or the applicable wage rate listed on this wage determination, if it is higher) for all hours spent performing on the contract in 2023.</li> </ul>
<p>If the contract was awarded on or between January 1, 2015 and January 29, 2022, and the contract is not renewed or extended on or after January 30, 2022:</p>	<ul style="list-style-type: none"> <li>. Executive Order 13658 generally applies to the contract.</li> <li>. The contractor must pay all covered workers at least \$12.15 per hour (or the applicable wage rate listed on this wage determination, if it is higher) for all hours spent performing on that contract in 2023.</li> </ul>

The applicable Executive Order minimum wage rate will be adjusted annually. If this contract is covered by one of the Executive Orders and a classification considered necessary for performance of work on the contract does not appear on this wage determination, the contractor must still submit a conformance request.

Additional information on contractor requirements and worker

protections under the Executive Orders is available at <http://www.dol.gov/whd/govcontracts>.

Modification Number	Publication Date
0	01/06/2023
1	01/13/2023
2	01/20/2023
3	02/10/2023
4	03/17/2023
5	04/28/2023
6	05/05/2023
7	05/12/2023
8	06/02/2023
9	07/28/2023

BOIL0013-005 01/01/2023

CENTRE, FRANKLIN, POTTER, CLINTON, FULTON, HUNTINDON AND MIFFLIN COUNTIES

	Rates	Fringes
BOILERMAKER.....	\$ 51.27	34.96

BOIL0154-004 01/01/2021

ALLEGHENY, ARMSTRONG, BEAVER, BEDFORD, BLAIR, BUTLER, CAMBRIA, CAMERON, CLARION, CLEARFIELD, CRAWFORD, ELK, FAYETTE, FOREST, GREENE, INDIANA, JEFFERSON, LAWRENCE, MCKEAN, MERCER, SOMERSET, VENANGO, WARREN, WASHINGTON AND WESTMORELAND COUNTIES

	Rates	Fringes
BOILERMAKER.....	\$ 43.90	29.55

BOIL0744-003 07/01/2008

ERIE COUNTY

	Rates	Fringes
BOILERMAKER.....	\$ 35.34	18.48

BRPA0005-033 05/01/2022

MIFFLIN COUNTY

	Rates	Fringes
Bricklayer, Stonemason.....	\$ 32.66	21.58

BRPA0005-046 05/03/2020

FRANKLIN COUNTY

	Rates	Fringes
Bricklayer, Stonemason.....	\$ 33.99	16.87

BRPA0005-071 05/03/2020

CLINTON COUNTY

	Rates	Fringes
BRICKLAYER.....	\$ 34.17	17.20
-----		
BRPA0009-004 12/01/2022		

BEDFORD, BLAIR,CAMBRIA, CENTRE COUNTY (Halfmoon, Houston, Patton, Rush,Taylor and Worth Townships),FULTON, HUNTINGDON, and SOMERSET COUNTIES

	Rates	Fringes
Bricklayer, Stonemason & Marble Setter.....	\$ 34.14	22.00
-----		
BRPA0009-006 12/01/2022		

CLEARFIELD, FOREST, JEFFERSON, VENANGO, AND CLARION (Except Brady, Madison, Perry, Porter, Redbank, and Toby Townships) COUNTIES

	Rates	Fringes
Bricklayer, Stonemason.....	\$ 34.14	22.77
Marble mason.....	\$ 34.14	22.77
-----		
BRPA0009-023 12/01/2022		

BEAVER COUNTY

	Rates	Fringes
BRICKLAYER.....	\$ 35.28	24.49
-----		
BRPA0009-025 12/01/2022		

BUTLER, LAWRENCE, AND MERCER COUNTIES

	Rates	Fringes
BRICKLAYER.....	\$ 34.73	24.14
-----		
BRPA0009-032 06/01/2017		

FAYETTE (Jefferson & Washington Twps), GREENE (Except Cumberland, Dunkirk, Greene, Monongahelia Twps), INDIANA, AND WESTMORELAND (Rostraver Twp) COUNTIES

	Rates	Fringes
BRICKLAYER.....	\$ 31.00	20.66
-----		
BRPA0009-033 12/01/2022		

ARMSTRONG, CLARION (Brady, Madison, Perry, Tobe, Porter, Redbank Twps), FAYETTE (Except Jefferson & Washington Twps), GREENE (Cumberland, Dunkirk, Greene, Monongahelia Twps), INDIANA, AND WESTMORELAND (Except Rostrave Twp) COUNTIES

	Rates	Fringes
--	-------	---------

BRICKLAYER.....\$ 36.55                   24.46  
-----  
BRPA0009-034 11/01/2019

ERIE COUNTY

	Rates	Fringes
BRICKLAYER.....	\$ 28.64	21.86
-----		
BRPA0009-058 06/01/2020		

ALLEGHENY, WASHINGTON (Cross Creek, Hanover, Jefferson, Mt Pleasant, Nottingham, Peters, Robinson, Smith, Union Twps) COUNTIES

	Rates	Fringes
BRICKLAYER.....	\$ 34.05	22.81
-----		
BRPA0009-059 12/01/2022		

CAMERON, ELK, McKEAN, POTTER AND WARREN COUNTIES

	Rates	Fringes
BRICKLAYER.....	\$ 31.62	22.81
-----		
CARP0274-001 01/01/2023		

	Rates	Fringes
PILEDRIVERMAN		
Piledriverman (welder).....	\$ 40.63	21.17
Piledriverman.....	\$ 39.13	21.17
-----		
CARP0274-002 01/01/2023		

	Rates	Fringes
Diver.....	\$ 58.70	21.17
Tender.....	\$ 39.13	21.17
-----		
* CARP0443-004 06/01/2023		

	Rates	Fringes
MILLWRIGHT.....	\$ 45.50	31.56%+9.01
-----		
CARP2274-001 01/01/2023		

	Rates	Fringes
CARPENTER (ALLEGHENY, ARMSTRONG, BEAVER, BUTLER, ERIE, FAYETTE, GREENE, LAWRENCE, MERCER, WASHINGTON, AND WESTMORELAND COUNTIES)		
Carpenters (Welders).....	\$ 40.10	20.59
Carpenters.....	\$ 38.60	20.59
CARPENTER (BEDFORD, BLAIR, CAMBRIA, CAMERON, CENTRE, CLARION, CLINTON, CLEARFIELD,		

CRAWFORD, ELK, FOREST,  
FRANKLIN, FULTON, HUNTINGDON,  
INDIANA, JEFFERSON, MCKEAN,  
MIFFLIN, POTTER, SOMERSET,  
VENANGO, AND WARREN COUNTIES)

Carpenters (Welders).....	\$ 39.85	20.59
Carpenters.....	\$ 38.35	20.59

-----  
ELEC0005-006 12/23/2022

ALLEGHENY, ARMSTRONG, BEDFORD, BLAIR, BUTLER CAMBRIA, CAMERON,  
CENTRE (Remainder), CLARION, CLEARFIELD, ELK, FAYETTE, FULTON,  
GREENE, HUNTINGDON, INDIANA, JEFFERSON, MCKEAN, SOMERSET,  
VENANGO, WASHINGTON, AND WESTMORELAND COUNTIES

	Rates	Fringes
ELECTRICIAN.....	\$ 46.86	29.66

-----  
ELEC0056-004 06/01/2023

ERIE, FOREST AND WARREN COUNTIES

	Rates	Fringes
ELECTRICIAN.....	\$ 38.94	25.26

-----  
ELEC0126-005 05/31/2021

ALLEGHENY, ARMSTRONG, BEAVER, BEDFORD, BLAIR, CAMBRIA, CENTRE,  
CLARION, CLEARFIELD, FAYETTE, FULTON, GREENE, HUNTINGDON,  
INDIANA, JEFFERSON, SOMERSET, WASHINGTON AND WESTMORELAND

	Rates	Fringes
Line Construction:		
Cable Splicer.....	\$ 50.33	32.25%+11.00
Groundman.....	\$ 30.20	32.25%+11.00
Lineman.....	\$ 50.33	32.25%+11.00
Truck Driver.....	\$ 32.71	32.25%+11.00
Winch Truck Operator.....	\$ 35.23	32.25%+11.00

-----  
ELEC0126-007 05/31/2021

FRANKLIN AND MIFFLIN COUNTIES

	Rates	Fringes
Line Construction:		
Cable Splicer.....	\$ 49.22	32.25%+11.00
Groundman.....	\$ 29.53	32.25%+11.00
Lineman.....	\$ 49.22	32.25%+11.00
Truck Driver.....	\$ 31.99	32.25%+11.00
Winch Truck Operator.....	\$ 34.45	32.25%+11.00

-----  
ELEC0143-007 06/01/2022

FRANKLIN and MIFFLIN COUNTIES

	Rates	Fringes
ELECTRICIAN.....	\$ 35.25	25.98

ELEC0712-003 12/26/2022

CRAWFORD, BEAVER, LAWRENCE AND MERCER COUNTIES

	Rates	Fringes
ELECTRICIAN.....	\$ 45.55	27.13

-----  
ELEC0812-008 06/01/2022

CLINTON COUNTY

	Rates	Fringes
ELECTRICIAN.....	\$ 36.31	23.64

-----  
ELEC0812-009 06/01/2022

POTTER COUNTY

	Rates	Fringes
ELECTRICIAN.....	\$ 37.32	23.67

-----  
ELEC0812-011 06/01/2022

CENTRE COUNTY (Burnside, Curtin, Liberty, Howard, Marion, Walker, Miles, Haines Townships)

	Rates	Fringes
ELECTRICIAN.....	\$ 36.31	23.64

-----  
ELEC1319-004 08/29/2022

BUTLER, CAMERON, CLINTON, CRAWFORD, ELK, ERIE, FOREST, LAWRENCE, MCKEAN, MERCER, VENANGO, WARREN AND POTTER COUNTIES

	Rates	Fringes
Line Construction:		
Equipment Operator.....	\$ 62.66	22.29
Groundmen.....	\$ 38.85	13.57
Linemen.....	\$ 62.66	27.29
Truck Driver.....	\$ 40.73	13.71

-----  
ENGI0066-016 01/01/2023

	Rates	Fringes
Power equipment operators: (ALLEGHENY, ARMSTRONG, BEAVER, BLAIR, BUTLER, CAMBRIA, CENTRE, CLARION, CLEARFIELD, CRAWFORD, ERIE, ELK, FAYETTE, GREENE, INDIANA, JEFFERSON, LAWRENCE, MCKEAN, MERCER, SOMERSET, VENANGO, WARREN, WASHINGTON, AND WESTMORELAND COUNTIES)		
GROUP 1.....	\$ 36.79	23.58
GROUP 1-A.....	\$ 39.79	23.58
GROUP 1-B.....	\$ 38.79	23.58

8/22/23, 10:30 AM

SAM.gov

GROUP 2.....	\$ 36.53	23.58
GROUP 3.....	\$ 32.88	23.58
GROUP 4.....	\$ 32.42	23.58
GROUP 5.....	\$ 32.17	23.58

Power equipment operators:  
 (BEDFORD, CAMERON, CLINTON,  
 FOREST, FRANKLIN, FULTON,  
 HUNTINGDON, MIFFLIN, AND  
 POTTER COUNTIES)

GROUP 1.....	\$ 36.50	23.58
GROUP 1-A.....	\$ 39.50	23.58
GROUP 1-B.....	\$ 38.50	23.58
GROUP 2.....	\$ 36.22	23.58
GROUP 3.....	\$ 32.58	23.58
GROUP 4.....	\$ 32.09	23.58
GROUP 5.....	\$ 31.88	23.58

POWER EQUIPMENT OPERATORS CLASSIFICATIONS

GROUP 1 - Asphalt Paving Machine (Spreader), Autograde (C.M.I. and similar); Backfiller, Compactor with Blade, Backhoe - 360 and 180 degree Swing; Cableway; Caisson Drill (similar to Hugh Williams), Central Mix Plant; Cooling Plant; Concrete Paving Mixer, Concrete Pump (self-propelled); Cranes; Cranes (boom or mast over 101ft.\$50 per each additional 50 feet inclusive of jib), Cranes (Tower Stationary- Climbing Tower Crane); Derrick; Derrick Boat; Dozer(greater than 25,000 lbs.); Dragline; Dredge; Dredge Hydraulic; Elevating Grader; Franki Pile Machine; Gradall (remote control or otherwise),Grader (power-fine grade); Hllift (4 cy. and over); Hoist 2 Drums or more (in one unit); Hydraulic Boom Truck with pivotal cab (single motor-Pitman or similar),Hydraulic Boom Truck (non pivotal cab); Hydro-pneumatic Excavation Equipment (or similar); (Boom and Mast over 101 feet will be paid an additional 50 feet inclusive of jib if used;) Kocal; Mechanic, Locomotive (std. Gauge); Metro-chip Harvester or similar; Milling Machine (Roto Mill or similar); Mix Mobile; Mix Mobile (with Self Loading Attachment), Mucking Machine (tunnel); Pile Driver Machine; Pipe Extrusion Machine; Presplitter Drill (self contained); Refrigeration Plant (soil Stabilization) Rough Terrain Crane (25 ton over) (Boom and Mast over 101 feet will be paid an additional 50 feet inclusive of jib if used); Rough Terrain Crane (under 25 ton), Scrapers; Shovel-Power; Slip form Paver (C.M.I. and similar); Trenching Machine (30,000 lbs. and over), Trenching Machine (under 30,000 lb.), Tunnell Machine (Mark XXI Jarva or similar), Vermeer Saw, Whirley, Mechanic, Compactor with blade

GROUP 1-A Backhoes-360 degree swing (above 120,000 lbs. gross weight); Cranes (over 100 tons), Cranes-Rough Terrain (over 100 ton); Tug Boat Pilot (on boats over 800 horsepower)

GROUP 1-B Backhoes-360 degree swing (above 70,000 lbs. to 120,000 lbs. gross weight); Cranes (up to 100 ton), Cranes-Rough Terrain (65 ton-100 ton), Tower Crane

GROUP 2: Asphalt plant operator; auger (tractor mtd.); auger (truck mtd.); belt loader (euclid or similar); boring machine; cable placer or layer; Directional drill over 3,000 lbs thrust; concrete batch plant (electronically synchronized); concrete belt placer (C.M.I. and similar); concrete finishing machine and spreader, concrete mixer (over 1 cy.) concrete pump (stationary); core drill (truck

<https://sam.gov/wage-determination/PA20230002/9>

7/16



or skid mtd. - similar to penn drill), dozer (25,000 lbs or less); Ditch Witch Saw, force feedloader; fork lift (lull or similar); grader - power; grease unit opertor (head); guard rail post driver (truck mounted) guard rail post driver (skid type); hilift (under 4 cy.); skid steer loader; hydraulic boom truck (non-pivotal cab); job work boat (powered), jumbo operator; locomotive (narrow guage); minor equipment operator (accumulative four units); mucking machine; multi-head saw (groover); overhead crane; roller -power- asphalt; ross carrier; side boom or tractor mounted boom; shuttle buggy (asphalt), stone crusher (screening-washing plants); stone spreader (self propelled) truck mounted drill (davey or similar); welder and repairman; well point pump operator; bidwell concrete finishing machine (or similar).

GROUP 3: Broom Finisher (C.M.I. or similar); Compactors/Rollers (static or vibratory (Self-propelled) on dirt or stone; Curb Builder; Minor Equipment Opertor (two or three units); Multi-head Tie Tamper; Pavement Breaker (self-propelled or ridden); Soil Stablizer Machine; Tire Repairman; Tractor (snaking and hauling); Well Driller and Horizontal: Winch or "A" Frame Truck (when hoisting and lowering).

GROUP 4: Ballast Regulator; Compressor; Concrete Mixer (1 cy. & under with skip); Concrete Saw (Ridden or selp-propelled); Conveyor; Elevator (Material hauling only); Fork-lift (Ridden or self-propelled); Form Line Machine; Generator; Groute Pump; Heater (Machinical); Hoist (single Drum); Ladavator, Light Plant; Mulching Machine; Personnel Boat (Powered), Pulverizer, Pumps, Seeding Machine, spray Cure Machine (powered Driven); Subgrader; Tie Puller; Tugger; Welding Machine (Gas or Diesel).

GROUP 5: Deck Hand; Farm Tractor; Fireman on Boiler; Oiler; Power Broom; Side Delivery Shoulder Spreader (attachment);

-----  
IRON0003-001 06/01/2023

ALLEGHENY, FAYETTE, WESTMORELAND, CAMBRIA, INDIANA, ARMSTRONG, BUTLER, BEAVER, CLARION, AND WASHINGTON COUNTIES

	Rates	Fringes
IRONWORKER.....	\$ 38.89	34.54

-----  
IRON0003-007 06/01/2023

BLAIR, CAMERON, CENTRE, CLEARFIELD, CLINTON, ELK, JEFFERSON, MCKEAN, AND POTTER COUNTIES

	Rates	Fringes
IRONWORKER.....	\$ 32.29	32.41

-----  
IRON0003-011 06/01/2023

CRAWFORD, ERIE, FOREST, AND WARREN COUNTIES

	Rates	Fringes
--	-------	---------

8/22/23, 10:30 AM

SAM.gov

IRONWORKER.....\$ 33.57 32.23

IRON0207-002 06/01/2023

LAWRENCE, MERCER, AND VENANGO COUNTIES

Rates Fringes

IRONWORKER.....\$ 33.00 27.16

IRON0404-008 07/01/2022

FRANKLIN (Remainder), HUNTINGDON (Remainder), AND MIFFLIN COUNTIES

Rates Fringes

IRONWORKER, STRUCTURAL.....\$ 35.26 31.13

IRON0549-002 12/01/2022

GREENE COUNTY

Rates Fringes

IRONWORKER.....\$ 35.19 25.66

IRON0568-004 05/01/2023

BEDFORD, FRANKLIN (Southwest 1/3), FULTON, HUNTINGDON (Western 2/3), AND SOMERSET COUNTIES

Rates Fringes

IRONWORKER

Structural, Ornamental, Reinforcing, Machinery Mover, Rigger & Machinery Erector, Welder, Fence Erector.....\$ 30.51

23.65

LABO1058-001 01/01/2023

Rates Fringes

LABORER (BEDFORD, CAMERON, CENTRE, CLINTON, CRAWFORD, FOREST, FRANKLIN, FULTON, HUNTINGDON, JEFFERSON, MIFFLIN, AND POTTER COUNTIES)

GROUP 1.....\$ 29.85 25.50
GROUP 2.....\$ 30.01 25.50
GROUP 3.....\$ 30.50 25.50
GROUP 4.....\$ 30.95 25.50
GROUP 5.....\$ 31.36 25.50
GROUP 6.....\$ 28.20 25.50
GROUP 7.....\$ 30.85 25.50
GROUP 8.....\$ 32.35 25.50

Laborers: (ALLEGHENY, ARMSTRONG, BEAVER, BLAIR, BUTLER, CAMBRIA, CLARION, CLEARFIELD, ELK, ERIE, FAYETTE, GREENE, INDIANA,

LAWRENCE, MCKEAN, MERCER,  
SOMERSET, VENANGO, WARREN,  
WASHINGTON, AND WESTMORELAND  
COUNTIES)

GROUP 1.....	\$ 29.95	25.50
GROUP 2.....	\$ 30.11	25.50
GROUP 3.....	\$ 30.50	25.50
GROUP 4.....	\$ 30.95	25.50
GROUP 5.....	\$ 31.36	25.50
GROUP 6.....	\$ 28.20	25.50
GROUP 7.....	\$ 30.95	25.50
GROUP 8.....	\$ 32.45	25.50

LABORERS CLASSIFICATIONS

GROUP 1: Asphalt curb sealer; Asphalt tamper; Batcherman (weigh) Blaster, Boatman, Brakeman, Change house attendant, Cofferdam, Concrete curing pitman, Puddler, Drill Runner's helper (Includes Drill Mounted on Truck, Track, or similar and Davey Drill Spots, Clean up, helps to maintain), Electric Brush and or Grinder, Fence Construction (Including Fence Machine Operator) Form stripper and Mover, Gabion (Erectors and Placers) Hydro jet blaster nozzleman; Landscape laborer, Manually moved emulsion sprayer, Radio actuated traffic control operator Rip rap work, scaffolds and Runways, Sheeters and Shorers (includes lagging) structural concrete Top Surfacers, Walk Behind Street Sweeper, and Wood Chipper; water boy

GROUP 2: Air tool operator (all types); Asphalt, batch & concrete plant operator (manually operated) Burner, Caisson; men (open air); Carryable pumps; Chain saw operator including attachments, Cribbing, (concrete or steel); Curb machine operator (asphalt or concrete walk behind); Diamond head Core Driller, Drill runner's helper (tunnel) Fork Lift, (walk behind), Form Setter (Road Forms Line man) Highway Slab reinforcement placers (including joint and Basket Setters) Hydraulic pipe pusher; Liner plates (Tile or Vitriified Clay) Mechanical compacting equipment operators, Mechanical joint sealer, Dope pot and Tar Kettle, Mortar mixer (hand or machine) Muckers, Brakemen & all other Labor, (Includes installation of utility lines) Pipe Layers /Fusion /Heating Iron (Regardless of materials) Portable Single Unit Conveyor, Post Hole Auger, (2 or 4 cycle hand operated) Power wheelbarrows and buggies, Rail porter or similar; Sand blaster; Signal Man, Vibrator operator, All RAILROAD TRACK WORK TO INCLUDE THE FOLLOWING: adzing machine, ballast Router, Bolting Machine, Power Jacks, Rail Drills, Railroad Brakeman, Rail Saws, Spike Drivers (Manually or hand held tool) Spike Pullers Tamping Machine, Thermitweld

GROUP 3: Asphalt Luteman/Raker, Blacksmith, Blaster, Brick, stone and block pavers and block cutters (wood, belgian and asphalt); Cement mortar lining car pusher; Cement mortar mixer (pipe relining); Cement mortar pipe reliners; concrete saw operator (walk behind); Curb cutters and setters; Elevated roadway drainage construction; erector of overhead signs, Form setter (road forms-lead man); Grout machine operator; Gunite or dry pack gun (nozzle and machine man); Manhole or catch basin builder (Brick block concrete or any prefabrication) Miners and drillers (including lining, supporting and form workmen, setting of shields, miscellaneous equipment and jumbos); Multi-plate pipe (aligning and securing); Placing wire mesh on gunite

projects; Wagon drill operators (air track or similar);  
Walk behind ditching machine (trencher or similar);crown  
screed adjuster and welder

GROUP 4: Reinforcing Steel Placer (Bending, aligning, and  
securing, Cadweld)

GROUP 5:High Burner, (Any burning not done from deck), Welder  
(Pipeline)

GROUP 6: Uniformed Flagperson, Watchman

GROUP 7: Toxic/Hazardous Waste Removal Laborer Levels C & D

GROUP 8: Toxic/Hazardous Waste Removal Laborer Levels A & B

-----  
PAIN0021-019 05/01/2021

CLINTON COUNTY

	Rates	Fringes
Painters:		
Bridge.....	\$ 36.67	18.80
Brush & Roller.....	\$ 29.02	21.14
Spray.....	\$ 30.02	21.14

-----  
PAIN0021-024 05/01/2021

FRANKLIN COUNTY

	Rates	Fringes
PAINTER		
Brush.....	\$ 25.84	16.30

-----  
PAIN0057-014 06/01/2021

ALLEGHENY, FAYETTE, GREENE, WASHINGTON COUNTIES

	Rates	Fringes
Painters:		
Bridge.....	\$ 36.25	21.61
Brush & Roller.....	\$ 29.15	21.61
Spray.....	\$ 29.15	21.61

-----  
PAIN0057-015 06/01/2021

ARMSTRONG, BEAVER, BEDFORD, BLAIR, BUTLER,CAMBRIA, CENTRE,  
CLARION, CLEARFIELD, ELK, FULTON, HUNTINGTON, INDIANA,  
JEFFERSON, LAWRENCE, MERCER, MIFFLIN, SOMERSET, VENANGO AND  
WESTMORELAND COUNTIES

	Rates	Fringes
Painters:		
Bridge.....	\$ 36.25	21.61
Brush and Roller.....	\$ 29.15	21.61
Spray.....	\$ 29.15	21.61

-----  
PAIN0057-022 05/01/2023

	Rates	Fringes
Painters: (ERIE, McKEAN, AND WARREN (Including Columbus and Freehold twps) COUNTIES)		
Bridges, Stacks, Towers.....	\$ 27.76	23.49
Brush and Roller.....	\$ 25.26	23.49
Spray and Sandblasting.....	\$ 26.01	23.49

-----  
PAIN0057-027 06/01/2020

CAMERON, CRAWFORD, POTTER, WARREN, (Excluding Columbus and Freehold twps)

	Rates	Fringes
PAINTER		
Brush and Roller.....	\$ 28.80	20.04

-----  
PLAS0526-002 01/01/2023

	Rates	Fringes
CEMENT MASON/CONCRETE FINISHER...	\$ 34.14	25.05

-----  
PLUM0027-001 06/01/2021

ALLEGHENY, ARMSTRONG, BEAVER, BUTLER, CLARION, GREENE (Except extreme Eastern portion), LAWRENCE, WASHINGTON (Except extreme Eastern portion) and WESTMORELAND (City of Arnold and City of New Kensington Only) COUNTIES

	Rates	Fringes
Plumbers and Pipefitters (Bridge Drain Pipe).....		
	\$ 44.45	24.57

-----  
PLUM0027-009 06/01/2021

CRAWFORD, ERIE, FOREST, MCKEAN, MERCER, VENANGO and WARREN COUNTIES

	Rates	Fringes
Plumbers and Pipefitters (Bridge Drain Pipe).....		
	\$ 42.78	24.57

-----  
PLUM0354-005 06/01/2012

BEDFORD, BLAIR, CAMBRIA, CAMERON, CLEARFIELD, ELK, FAYETTE, GREENE (Extreme Eastern portion), HUNTINGDON, INDIANA, JEFFERSON, SOMERSE, WASHINGTON (Extreme Eastern portion), AND WESTMORELAND COUNTIES

	Rates	Fringes
Plumbers and Pipefitters (Bridge Drain Pipe).....		
	\$ 35.54	19.97

-----  
TEAM0040-006 01/01/2023

Rates Fringes

TRUCK DRIVER (ALLEGHENY, ARMSTRONG, BEAVER, BLAIR, BUTLER, CAMBRIA, CENTRE, CLARFIELD, CRAWFORD, ERIE, FAYETTE, GREENE, INDIANA, JEFFERSON, LAWRENCE, MCKEAN, MERCER, SOMERSET, VENANGO, WARREN, WASHINGTON, AND WESTMORELAND)		
GROUP 1.....	\$ 33.18	22.21
GROUP 2.....	\$ 33.64	22.52
Truck drivers: (BEDFORD, CAMERON, CLAIRON, CLINTON, ELK, FOREST, FRANKLIN, FULTON, HUNTINGDON, MIFFLIN, AND POTTER COUNTIES)		
GROUP 1.....	\$ 33.04	22.13
GROUP 2.....	\$ 33.50	22.43

FOOTNOTES: A. Hazardous/toxic waste material/work level A & B receive additional \$2.50 per hour above classification rate

B. Hazardous/toxic waste materials/Work level C & D receive \$1.00 per hour above classification

TRUCK DRIVERS CLASSIFICATIONS

GROUP 1 - Single Axle (2 axles including steering axle); Includes partsman and warehoueman. Tandem - Tri-Axle - Semi-Tractor Trailer (combination) (3 axles or more including steering axle)

GROUP 2 - Specialty Vehicles; Heavy equipment whose capacity exceeds that for which state licenses are issued specifically refers to units in excess of eight (8) feet width (such as Euclids, Atley Wagon, Payloader, Tournawagons, and similar equipment when not self loaded); Tar and Asphalt Distributors Trucks, Heavy Duty Trailer, such as Low Boy, High Boy

WELDERS - Receive rate prescribed for craft performing operation to which welding is incidental.

Note: Executive Order (EO) 13706, Establishing Paid Sick Leave for Federal Contractors applies to all contracts subject to the Davis-Bacon Act for which the contract is awarded (and any solicitation was issued) on or after January 1, 2017. If this contract is covered by the EO, the contractor must provide employees with 1 hour of paid sick leave for every 30 hours they work, up to 56 hours of paid sick leave each year. Employees must be permitted to use paid sick leave for their own illness, injury or other health-related needs, including preventive care; to assist a family member (or person who is like family to the employee) who is ill, injured, or has other health-related needs, including preventive care; or for reasons resulting from, or to assist a family member (or person who is like family to the employee) who is a victim of, domestic violence, sexual assault, or stalking. Additional information

on contractor requirements and worker protections under the EO is available at <https://www.dol.gov/agencies/whd/government-contracts>.

Unlisted classifications needed for work not included within the scope of the classifications listed may be added after award only as provided in the labor standards contract clauses (29CFR 5.5 (a) (1) (ii)).

-----  
The body of each wage determination lists the classification and wage rates that have been found to be prevailing for the cited type(s) of construction in the area covered by the wage determination. The classifications are listed in alphabetical order of "identifiers" that indicate whether the particular rate is a union rate (current union negotiated rate for local), a survey rate (weighted average rate) or a union average rate (weighted union average rate).

#### Union Rate Identifiers

A four letter classification abbreviation identifier enclosed in dotted lines beginning with characters other than "SU" or "UAVG" denotes that the union classification and rate were prevailing for that classification in the survey. Example: PLUM0198-005 07/01/2014. PLUM is an abbreviation identifier of the union which prevailed in the survey for this classification, which in this example would be Plumbers. 0198 indicates the local union number or district council number where applicable, i.e., Plumbers Local 0198. The next number, 005 in the example, is an internal number used in processing the wage determination. 07/01/2014 is the effective date of the most current negotiated rate, which in this example is July 1, 2014.

Union prevailing wage rates are updated to reflect all rate changes in the collective bargaining agreement (CBA) governing this classification and rate.

#### Survey Rate Identifiers

Classifications listed under the "SU" identifier indicate that no one rate prevailed for this classification in the survey and the published rate is derived by computing a weighted average rate based on all the rates reported in the survey for that classification. As this weighted average rate includes all rates reported in the survey, it may include both union and non-union rates. Example: SULA2012-007 5/13/2014. SU indicates the rates are survey rates based on a weighted average calculation of rates and are not majority rates. LA indicates the State of Louisiana. 2012 is the year of survey on which these classifications and rates are based. The next number, 007 in the example, is an internal number used in producing the wage determination. 5/13/2014 indicates the survey completion date for the classifications and rates under that identifier.

Survey wage rates are not updated and remain in effect until a new survey is conducted.

#### Union Average Rate Identifiers

Classification(s) listed under the UAVG identifier indicate

that no single majority rate prevailed for those classifications; however, 100% of the data reported for the classifications was union data. EXAMPLE: UAVG-OH-0010 08/29/2014. UAVG indicates that the rate is a weighted union average rate. OH indicates the state. The next number, 0010 in the example, is an internal number used in producing the wage determination. 08/29/2014 indicates the survey completion date for the classifications and rates under that identifier.

A UAVG rate will be updated once a year, usually in January of each year, to reflect a weighted average of the current negotiated/CBA rate of the union locals from which the rate is based.

-----  
 WAGE DETERMINATION APPEALS PROCESS

1.) Has there been an initial decision in the matter? This can be:

- \* an existing published wage determination
- \* a survey underlying a wage determination
- \* a Wage and Hour Division letter setting forth a position on a wage determination matter
- \* a conformance (additional classification and rate) ruling

On survey related matters, initial contact, including requests for summaries of surveys, should be with the Wage and Hour National Office because National Office has responsibility for the Davis-Bacon survey program. If the response from this initial contact is not satisfactory, then the process described in 2.) and 3.) should be followed.

With regard to any other matter not yet ripe for the formal process described here, initial contact should be with the Branch of Construction Wage Determinations. Write to:

Branch of Construction Wage Determinations  
 Wage and Hour Division  
 U.S. Department of Labor  
 200 Constitution Avenue, N.W.  
 Washington, DC 20210

2.) If the answer to the question in 1.) is yes, then an interested party (those affected by the action) can request review and reconsideration from the Wage and Hour Administrator (See 29 CFR Part 1.8 and 29 CFR Part 7). Write to:

Wage and Hour Administrator  
 U.S. Department of Labor  
 200 Constitution Avenue, N.W.  
 Washington, DC 20210

The request should be accompanied by a full statement of the interested party's position and by any information (wage payment data, project description, area practice material, etc.) that the requestor considers relevant to the issue.

3.) If the decision of the Administrator is not favorable, an interested party may appeal directly to the Administrative Review Board (formerly the Wage Appeals Board). Write to:



8/22/23, 10:30 AM

SAM.gov

Administrative Review Board  
U.S. Department of Labor  
200 Constitution Avenue, N.W.  
Washington, DC 20210

4.) All decisions by the Administrative Review Board are final.

=====

END OF GENERAL DECISIO"

---

## **Notes for 33 County Heavy and Highway Laborers \* (See below)**

Allegheny, Armstrong, Beaver, Bedford, Blair, Butler, Cambria, Cameron, Centre, Clarion, Clearfield, Clinton, Crawford, Elk, Erie, Fayette, Forest, Franklin, Fulton, Greene, Huntingdon, Indiana, Jefferson, Lawrence, McKean, Mercer, Mifflin, Potter, Somerset, Venango, Warren, Washington & Westmoreland

### **HEAVY AND HIGHWAY**

#### **CLASS 1 - COMMON LABORER**

Asphalt Curb Sealer  
Batcher Man (Weight)  
Boatman  
Coffer Dam  
Drill Runner's Assistant  
Fence Construction (Including Fence Machine Operator)  
GABION (Erectors and Placers)  
Landscape Laborers  
Radio Actuated Traffic Control Operator  
RIP RAP Work  
Sheeters and Shorers (Includes Lagging)  
Water Boy  
Wood Chipper  
Asphalt Tamper  
Blaster's Assistant  
Brakeman  
Concrete Curing Pitman, Puddler  
Electric Bursh and/or Ginder  
Form Stripper and Mover  
Hydro Jet Blaster Nozzle Man  
Manually Moved Emulsion Sprayer  
(Bending, Aligning & Securing)  
Scaffolds and Runways  
Structural Concrete Top Surfacers  
Walk Behind Street Sweeper  
Welder's Assistant (Pipeline)

#### **CLASS 2 – SEMI-SKILLED LABORER**

Air Tool Operator (All Types)  
Railroad Track Work  
Burner

Carryable Pumps  
Cribbing (Concrete or Steel)  
Diamond Head Core Driller  
Drill Runner's Assistant (Tunnel)  
Highway Slab Reinforcement  
Placers (Including Joint and Backer Setters)  
Mechanical Joint Sealer; Dope Pot & Tar Kettle  
Pipe Layers/Fusion Welders (Regardless of Materials)  
Post Hole Auger (2 or 4 Cycle-Hand Operated)  
Forklift (Walk Behind)  
Asphalt, Batch and Concrete Plant  
Operator (Manually Operated)  
Caisson Men (Open Air)  
Chain Saw Operator (Including Attachments)  
Curb Machine Operator (Asphalt or Concrete-Walk Behind)  
Form Setter (Road Forms Line Man)  
Hydraulic Pipe Pusher  
Liner Plates (Tile and Vitrified Clay)  
Mechanical Compacting Equipment Operators  
Mortar Mixer (Hand or Machine)  
Muckers, Brakeman and All Other Labor (Includes Installation of Utility Lines)  
Portable Single Unit Conveyor  
Power Wheel Barrows and Buggies  
Aid Porter or Similar  
Sand Blaster  
Vibrator Operator  
All Railroad Track Work  
Signal Man

**CLASS 3 - SKILLED LABORER  
HEAVY AND HIGHWAY**

Asphalt Luteman/Raker  
Blacksmith  
Cement Mortar Lining Car Pusher  
Cement Mortar Mixer (Pipe Relining)  
Concrete Saw Operator (Walk Behind)  
Crown Screed Adjuster  
Elevated Roadway Drainage Construction  
Erector of Overhead Signs  
Miners and Drillers (Including Lining M Supporting and Form Workman, Setting of Shields,  
Miscellaneous Equipment and Jumbos)  
Walk Behind Ditching Machine (Trencher Or Similar)  
Blaster  
Brick, Stone & Block Pavers and Block Cutters (Wood-Belgian-Asphalt)  
Cement Mortar Pipe Reliners

---

Curb Cutters and Setters  
Form Setter (Road Forms-Lead Man)  
Gunitite or Dry Pack Gun-Nozzle and Machine Man  
Grout Machine Operator  
Multi-Plate Pipe (Aligning and Securing)  
Manhole or Catch Basin Builder  
Placing Wire Mesh on Gunitite Projects  
Wagon Drill Operator (Air Track or Similar)  
Welder

**CLASS 4**

Reinforcing Steel Placers (Bending, Aligning and Securing - Caldwell)

**CLASS 5**

High Burner (Any Burning Not Done From Deck)  
Elder (Pipeline)

**CLASS 6**

Uniformed Flag Person/Signal Person (As per PENN DOT Specifications on Hardhats and  
Vests)  
Watchman

**CLASS 7**

Toxic/Hazardous Waste Removal Laborer – Level C and D

**CLASS 8**

Toxic/Hazardous Waste Removal Laborer Levels A and B

*\*These notes pertain to projects whose rates were determined subsequent to March 23, 2009.  
Questions regarding rates prior to that date should be directed to the Bureau of Labor Law  
Compliance at 1-800-932-0665.*

---

## **Definitions for Heavy & Highway Operators in the 33 County Area**

Allegheny, Armstrong, Beaver, Bedford, Blair, Butler, Cambria, Cameron, Centre, Clarion, Clearfield, Clinton, Crawford, Elk, Erie, Fayette, Forest, Franklin, Fulton, Greene, Huntingdon, Indiana, Jefferson, Lawrence, McKean, Mercer, Mifflin, Potter, Somerset, Venango, Warren, Washington, & Westmoreland

### CLASS I-A

Backhoes – 360° swing (above 120,000 lbs.

gross weight)

Cranes (over 100 ton) \*

Cranes – Rough Terrain (over 100 ton) \*

\*Requires an Oiler on Standard Agreement

### CLASS I-B

Backhoes – 360° swing (above 70,000 lbs. to 120,000 lbs. gross weight)

Cranes (up to 100 ton) \*

Cranes – Rough Terrain (65 ton - 100 ton) \*

Tower Crane \*

\*Requires an Oiler on Standard Agreement

### CLASS I

Asphalt Paving Machine (Spreader)

Autograder/Trimmer

Backfiller

Backhoe -360° swing (up to 70,000 lbs. gross weight)

Backhoe (Rear pivotal swing -180° swing)

Bidwell Concrete Finishing Machine (or similar)

\*Caisson Drill (similar to Hugh Williams)

\*Cooling Plant

Compactor with blade

Concrete Batch Plant (Electronically Synchronized)

Concrete Crusher

Concrete Paving Mixer

Concrete Pump (Self-propelled)

Derrick

\*Derrick Boat

Dozer (with a gross weight of 25,000 lbs. and over)

\*Dragline

\*Dredge

Dredge Hydraulic (1 Leverman - 1 Oiler - 1 Apprentice)

Elevating Grader

\*Gradall (Remote control or otherwise)

---

Grader (Power-Fine Grade)  
Grease Unit Operator (Head)  
Hillift (4 cy. and over)  
Hoist 2 Drums or more (in one unit)  
Hydraulic Boom Truck (with pivotal cab) (single motor –  
Pitman or similar)  
\*Locomotive (Std. Gauge)  
\*Metro-chip Harvester or similar  
Mechanic  
Milling Machine (Roto Mill or Similar)  
\*Mix Mobile  
\*\*Mix Mobile (with Self Loading Attachment)  
Mucking Machine (Tunnel)  
\*Pile Driver Machine  
Pipe Bursting Machine  
Pipe Extrusion Machine  
Presplitter Drill (Self-contained)  
\*\*Refrigeration Plant (Soil stabilization)  
\*Rough Terrain Crane (under 65 ton)  
Scrapers  
\*Shovel-Power  
Shuttle Buggy (Asphalt)  
Slip Form Paver/Curb Machine  
Slip Lining Machine  
Soil Stabilizer Machine  
\*Trenching Machine (30,000 lb. and over)  
Trenching Machine (under 30,000 lb.)  
\*Tunnel Machine (Mark XXI Jarva or similar)  
Vermeer Saw  
Working Mechanical Foreman (plus \$0.35 per hour over  
Class I Rate)

---

\*Apprentice Engineer or Oiler required  
\*\*Two Engineers required

#### CLASS II

Asphalt Plant Operator  
Auger (Tractor Mtd.)  
Auger (Truck Mtd.)  
Belt Loader (Euclid or Similar)  
Boring Machine  
Cable Placer or Layer  
Concrete Placer and Spreader  
Concrete Mixer (over 1 cy.)

---

Concrete Pump (Stationary)  
\*Core Drill (Truck or Skid Mtd. - similar to Penn Drill)  
Directional Drills over 3,000 lbs. thrust  
Dozer (with a gross weight under 25,000 lbs.)  
Ditch Witch - Saw  
Force Feed Loader  
Fork Lift (Lull or similar)  
Grader - Power  
Guard Rail Post Driver (Truck Mounted)  
Guard Rail Post Driver (Skid Type)  
Hillift (under 4 cy.)  
Hydraulic Boom Truck (Non-pivotal cab)  
Job Work Boat (Powered) (When assistance is required it shall be a Deckhand)  
Jumbo Operator  
Locomotive (Narrow Gauge)  
Minor Equipment Operator  
Mucking Machine  
Multi-head Saw (Groover)  
Over-head Crane  
Roller-power-asphalt  
Ross Carrier  
Side Boom or tractor mounted boom  
Skid Steer Loader  
Stone Crusher (Screening-Washing Plants)  
Stone Spreader (Self-propelled)  
\*Truck Mounted Drill (Davey or similar)  
Welder and Repairman  
Well Point Pump Operator

---

\*Apprentice Engineer or Oiler required  
Pile driving operations: On truck cranes and crawler rigs the Company will employ an apprentice who will oil on the rig and also cover the minor machines regardless of size related to his operation, not to exceed four (4) units.

CLASS III  
Concrete Texture/Cure Machine  
Compactors/Rollers (Static or Vibratory) (Self-propelled)  
Curb Builder  
Multi-head Tie Tamper  
Pavement Breaker (Self-propelled or ridden)  
Tire Repairman (as per agreement with Teamsters)  
Tractor (Snaking and hauling)

Well Driller and Horizontal  
Winch or "A" Frame Truck (when hoisting and lowering)

CLASS IV

Ballast Regulator  
Concrete Mixer (1 cy. and under with skip)  
Concrete Saw (Ridden or self-propelled)  
Conveyor  
Elevator (Material hauling only)  
Fork-lift (Ridden or self-propelled)  
Generator  
Grout Pump  
Heater (Mechanical)  
Hoist (single drum)  
Ladavator  
Light Plant  
Mulching Machine  
Personnel Boat (Powered)  
Pulverizer  
Pumps  
Seeding Machine  
Tie Puller  
Tugger  
Welding Machine (Gas or Diesel)

CLASS V

Deck Hand  
Farm Tractor  
Fireman on Boiler  
Mechanic's Helper  
Oiler  
Power Broom  
Side Delivery Shoulder Spreader (Attachment)



## Appendix C



REINFORCING STEEL SCHEDULE

ITEM	LOCATION	NO. REQ'D	BAR SPACING	SIZE	CUT LENGTH	TOTAL LENGTH	TOTAL WEIGHT	SHAPE
1	PAD TOP	104	EQUALLY	#10	36'-6"	3796'	16361 LBS	STRAIGHT
2	PAD BOTTOM	104	EQUALLY	#10	36'-6"	3796'	16361 LBS	STRAIGHT
3	PIER VERTICAL	84	EQUALLY	#8	7'-10"	658'	1763 LBS	—
4	PIER TIES	42	4" C/C	#4	15'-6"	651'	442 LBS	○

TOTAL REBAR WEIGHT 34927 LBS

GENERAL TOWER NOTES:

1. WELDED CONNECTIONS SHALL CONFORM TO THE LATEST REVISION OF THE AMERICAN WELDING SOCIETY AWS. D 1.1.
2. TOWER AND ALL FABRICATED ACCESSORIES ARE HOT-DIP GALVANIZED.
3. ALL BOLTS SHALL BE GALVANIZED ACCORDING TO THE STANDARD SPECIFICATION FOR ZINC COATING OF IRON AND STEEL HARDWARE ASTM A153.
4. LEG STEEL IS 50 KSI MIN YIELD SOLID ROUND OR PIPE AND BRACING STEEL IS 36 KSI MIN YIELD SOLID ROUND OR A529-50 STRUCTURAL ANGLE.
5. ALL STRUCTURAL BOLTS ARE ASTM A325.
6. TOWER SHOULD BE INSPECTED IN ACCORDANCE WITH TIA-222-H EVERY 5 YEARS.
7. TOWER INSPECTION SHOULD ONLY BE PERFORMED BY EXPERIENCED QUALIFIED PERSONNEL. FOR ASSISTANCE IN PROPER MAINTENANCE OF YOUR TOWER, CALL WORLD TOWER AT 270-247-3642.



**WORLD TOWER**

1213 COMPRESSOR DRIVE  
MAYFIELD, KY 42066  
P: 270-246-3642 F: 270-247-0909  
WWW.WORLDTOWER.COM

SEAL



10-4-2024

R1	ADDED REINFORCEMENT	LKC	10-1-24
REV.	DESCRIPTION	BY	DATE

190' MODEL WSST TOWER  
FOR: UPWARD BROADBAND  
SITE: MINE GAP / HARRISONVILLE  
FULTON COUNTY, PA

SCALE	NONE	DWN.	LKC	CHKD.	DATE	9-30-24
FILE				DWG. NO.	Q2404-30N	

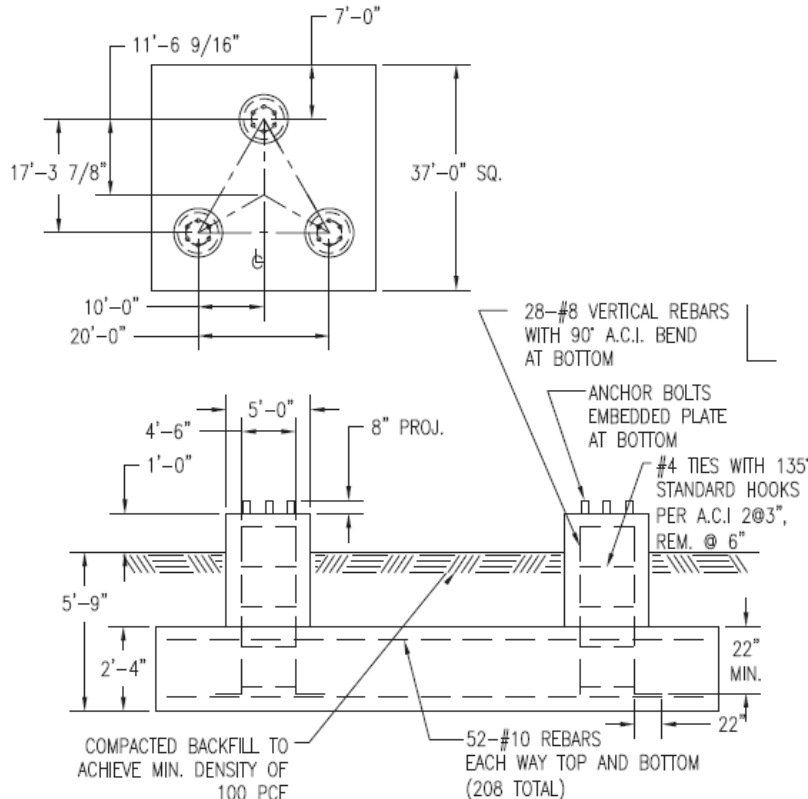
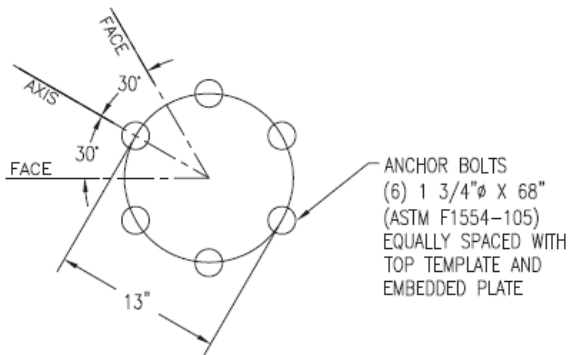
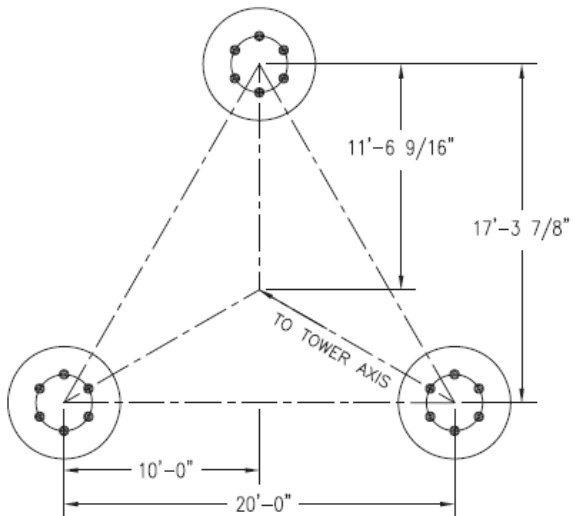
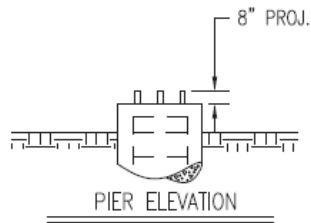

**FOUNDATION NOTES**

1. CONCRETE TO HAVE 4000 PSI MINIMUM COMPRESSIVE STRENGTH AFTER 28 DAYS.
2. ALL REINFORCEMENT STEEL IS DEFORMED AND MEETS THE STRENGTH REQUIREMENTS OF ASTM A615 GRADE 60.
3. EMBEDDED STEEL TO HAVE 3" MINIMUM CONCRETE COVER ±1/2".
4. FOUNDATION DESIGN IS BASED UPON CUSTOMER SUPPLIED SOILS DATA BY KLEINFELDER. PROJECT NUMBER 24004893.001A DATED MARCH 27, 2024.

128.0 TOTAL CU. YDS.  
CONCRETE REQ'D.

BASE REACTIONS	
OTM:	14482.0 FT. KIPS
COMP.	870.0 KIPS
UPLIFT	781.0 KIPS
SHEAR (3 LEGS)	120.0 KIPS
WT. NO ICE	101.0 KIPS
WT. 1" ICE	185.0 KIPS



**WORLD TOWER**

1213 COMPRESSOR DRIVE  
MAYFIELD, KY 42066  
P: 270-246-3642 F: 270-247-0909  
WWW.WORLDTOWER.COM

SEAL



10-18-2024

REV.	DESCRIPTION	BY	DATE
R1	ADDED DETAILS	LKC	10-18-24

190' MODEL WSST TOWER  
FOR: UPWARD BROADBAND  
SITE: MINE GAP / HARRISONVILLE  
FULTON COUNTY, PA

SCALE	NONE	DWN.	LKC	CHKD.	DATE	7-25-24
FILE				DWG. NO.	Q240430	

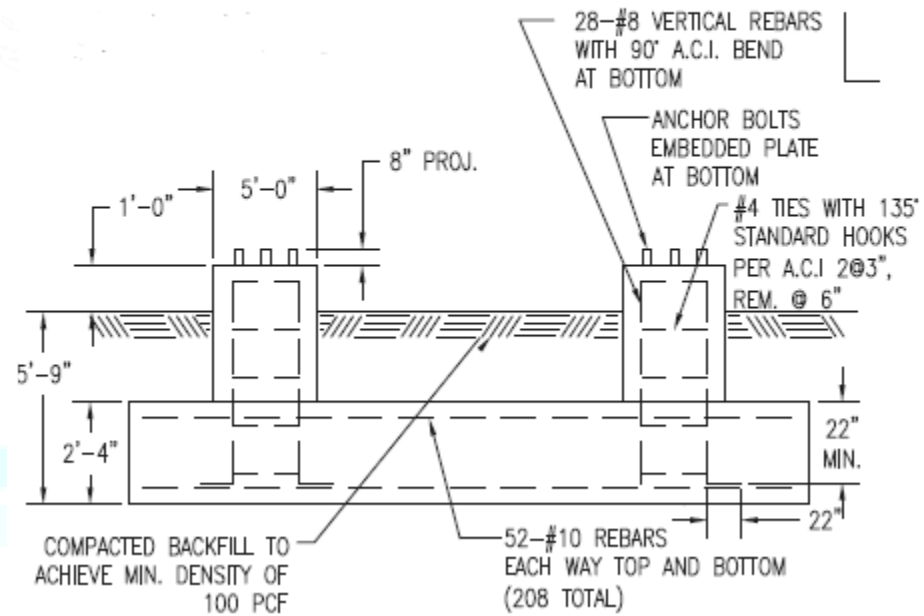

DRUVAUDAN

## Non-Collusion Affidavit

State of \_\_\_\_\_

County of \_\_\_\_\_

\_\_\_\_\_, being first duly sworn, deposes and says that:

- (1) She/He is the \_\_\_\_\_ (owner, partner, officer, representative or agent) of the Proposer that had submitted the attached proposal.
- (2) She/He is fully informed with respect to the preparation and contents of the attached proposal and of all pertinent circumstances respecting such proposal.
- (3) As such, the proposal is genuine and is not part of any conspiracy, collusion or deception.
- (4) Neither the said responder nor any of its officers, partners, owners, agents, representatives, employees or parties in interest, including this affiant, has in any way colluded, conspired, connived or agreed, directly or indirectly with any other responder, firm or person to submit a collusive or sham proposal in connection with the contract for which the attached proposal has been submitted or to refrain from proposing in connection with such contract, or has in any manner, directly or indirectly, sought by agreement or collusion or communication or conference with any other proposer, firm or person to fix the price or prices in the attached proposal or of any other responder, or to fix any overhead, profit or cost element for the prices or the proposal price of any responder, or to secure person interested in the proposed contract; and the price or prices quoted in the attached proposal are fair and proper and are not tainted by any collusion, conspiracy, connivance or unlawful agreement on the part of the responder or any of its agents, representatives, owners, employees, or parties in interest, including this affiant.
- (5) The price(s) and amount of this proposal have been arrived at independently and without consultation, communication or agreement with any other contractor, proposer, or potential proposer.
- (6) Neither the price(s) nor the amount of this proposal, and neither the approximate prices(s) nor the approximate amount of this proposal, have been disclosed to any other firm or person who is a responder/proposer or potential proposer, and they will not be disclosed before proposal opening.
- (7) No attempt has been made or will be made to induce any firm or person to refrain from submitting a proposal on this contract, or to submit a proposal higher than its proposal,

or to submit any intentionally high or noncompetitive proposal or other form of complementary proposal.

(8) The proposal of my firm is made in good faith and not pursuant to any agreement or discussion with, or inducement from, any firm or person to submit a complementary or other noncompetitive proposal.

(9) The above representations are material and important, and will be relied on by Upward Broadband in awarding the contract(s) for which this proposal is submitted. I understand and my firm understands that any misstatement in this affidavit is and shall be treated as fraudulent concealment from Upward Broadband of the true facts relating to the submission of proposals for this contract.

(Signed) \_\_\_\_\_

\_\_\_\_\_

(Printed Name)

\_\_\_\_\_

(Title)

Subscribed and sworn to me before this \_\_\_\_\_ day of \_\_\_\_\_,

2023.

\_\_\_\_\_  
Name

\_\_\_\_\_  
Title

My commission expires \_\_\_\_\_

## Responders Signature Form

Responder \_\_\_\_\_

Proposal must be signed here \_\_\_\_\_

Address \_\_\_\_\_

\_\_\_\_\_

Telephone Number \_\_\_\_\_

### Individual Partnership or Corporation

The responder certifies that they come under the class checked below:

**Please insert the appropriate names:**

A. Individual Owner \_\_\_\_\_

B. Partnership Partners \_\_\_\_\_

C. Corporation \_\_\_\_\_

Exact Name of Corporation

\_\_\_\_\_

State Incorporated

#### **Note:**

Proposals should be as net prices and shall prevail in the awarding contracts.

Failures of the responders to sign the proposal and have the signature of an authorized representative or agent on the proposal in the space provided, will be cause for rejection of the proposal.

Signatures must be written in ink. Typed, printed, or stamped signatures will not be accepted.

**DEBARMENT CERTIFICATION FORM**

The Proposer certifies that, neither the firm nor any owner, partner, director, officer, or principal of the Proposer, nor any person in a position with management responsibility or responsibility for the administration of federal funds:

(a) Is presently debarred, suspended, proposed for debarment, and declared ineligible or voluntarily excluded from covered transactions by any federal or state department/agency;

(b) Has within a three-year period preceding this certification been convicted of or had a civil judgment rendered against it for: commission of fraud or a criminal offense in connection with obtaining, attempting to obtain, or performing a public transaction or contract (federal, state, or local); violation of federal or state antitrust statutes; or commission of embezzlement, theft, forgery, bribery, falsification or destruction of records, making false statements, or receiving stolen property;

(c) Is presently indicted for or otherwise criminally or civilly charged by a governmental entity (federal, state, or local) with commission of any of the offenses enumerated in paragraph (b) above; or

(d) Has within a three-year period preceding this certification had one or more public transactions or contracts (federal, state, or local) terminated for cause or default.

The Proposer further certifies that it shall not knowingly enter into any transaction with any subcontractor, material supplier, or vendor who is debarred, suspended, declared ineligible, or voluntarily excluded from covered transactions by any federal or state department/agency.

Dated this \_\_\_\_\_ day of \_\_\_\_\_, 20 \_\_\_\_\_

By \_\_\_\_\_  
Authorized Signature

\_\_\_\_\_  
Printed Name and Title

\_\_\_\_\_  
Company Name